



Cam Units CHV  
Schieber CHV  
Unità a Camme CHV



**MCR**<sup>®</sup>  
STANDARD DIE COMPONENTS



## AERIAL CAM UNIT - OBEN HÄNGENDER SCHIEBER - UNITÀ A CAMME SOSPESA

	OMCR CODE	Work Angle	Slider Width (mm)	Closed Cam Height (mm)	Work Area W x H (mm)	Max Work Force with shoulder 10 <sup>6</sup> cycles (kN)	Extraction Force (kN)	Page number
		$\beta$				Fs	Ef	
EUROPEAN PATENT EP2241387	CHV050	0°÷75° (5° steps)	50	175÷195	50x100	92÷110	4,5÷6,1	726
	CHV060	0°÷75° (5° steps)	60	210	60x100	136÷143	5,1÷6,2	730
	CHV085	0°÷75° (5° steps)	85	225	85x120	229÷293	7,10÷12	734
	CHV110	0°÷75° (5° steps)	110	275	110x160	357÷407	6,2÷16,8	738
	CHV150	0°÷75° (5° steps)	150	300	150x160	421÷584	17,3÷20,8	742
	CHV180	0°÷75° (5° steps)	180	300	180x160	474÷598	17,1÷20,5	746
	CHV220	0°÷75° (5° steps)	220	300	220x160	635÷732	16,6÷46,2	750
	CHV260	0°÷75° (5° steps)	260	300	260x160	536÷767	16,6÷46,2	754
	CHV330	0°÷75° (5° steps)	330	375	330x180	1005÷1020	46,5÷94,9	758
	CHV400	0°÷75° (5° steps)	400	375	400x180	1052÷1055	48÷87,1	762
	CHV500	0°÷75° (5° steps)	500	375	500x180	1155	64,5÷87,0	766
	CHV600	0°÷75° (5° steps)	600	400	600x200	1202	84,2÷98,2	772

Cam Units CHV



Leading edge five axis machines



## AERIAL CAM UNIT - OBEN HÄNGENDER SCHIEBER - UNITÀ A CAMME SOSPESA

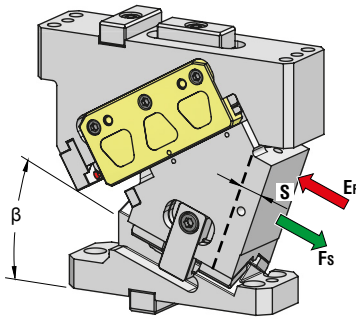

OMCR CODE	Work Angle	Stroke (mm)	Max Work Force with shoulder (kN)	Extraction Force (kN)
	$\beta$	S	$F_s$	$F_f$ Gas Spring
CHV050.00	0°	28,93	92	4,5
CHV050.05	5°	31,94	92	4,8
CHV050.10	10°	35,00	92	4,8
CHV050.15	15°	38,16	92	4,8
CHV050.20	20°	41,47	92	4,8
CHV050.25	25°	45,00	92	4,8
CHV050.30	30°	48,83	92	4,8
CHV050.35	35°	53,06	92	4,8
CHV050.40	40°	57,85	92	4,8
CHV050.45	45°	63,40	92	4,8
CHV050.50	50°	62,23	92	4,6
CHV050.55	55°	59,28	98	4,7
CHV050.60	60°	60,00	104	5,1
CHV050.65	65°	59,16	110	5,3
CHV050.70	70°	58,48	110	5,7
CHV050.75	75°	57,96	110	6,1

### OPTION CODE

SW	60 mm
----	-------

15



Art.	Work Angle = 5°	OPTION CODE
CHV050	05	SW60

OMCR CODE	Work Angle	Overall Dimensions (mm)													
		$\beta$	A	B	C	D	E	F	G	H	I	J	K	L	M
CHV050.00	0°	170	57	38	193	155	129	120	60	162	160	180	175	68,5	20
CHV050.05	5°	173,89	60,44	35	190	155	129	120	60	167	165	185	175	68,5	20
CHV050.10	10°	177,66	64,77	32	187	155	129	120	60	172	170	190	175	68,5	20
CHV050.15	15°	180,31	67,99	28	183	155	129	120	60	177	175	195	175	68,5	20
CHV050.20	20°	180,87	71,09	22	177	155	129	120	60	177	175	195	175	68,5	20
CHV050.25	25°	180,34	74,06	16	171	155	129	120	60	177	175	195	175	68,5	20
CHV050.30	30°	180,72	76,89	10	165	155	129	120	60	179	177	197	175	68,5	20
CHV050.35	35°	179,04	79,58	3	158	155	129	120	60	179	177	197	175	68,5	20
CHV050.40	40°	176,31	83,12	-9	146	155	129	120	60	179	177	197	175	68,5	20
CHV050.45	45°	172,54	85,51	-18	137	155	129	120	60	177	175	195	175	68,5	20
CHV050.50	50°	161,73	93,74	-33	122	155	129	120	60	172	170	190	180	68,5	20
CHV050.55	55°	168,28	97,72	-39	116	155	129	120	45	172	170	190	185	75	80
CHV050.60	60°	173,67	104,06	-49	106	155	129	120	45	172	170	190	190	85	80
CHV050.65	65°	169,28	113,98	-53	92	145	119	110	45	172	170	190	195	90	80
CHV050.70	70°	166,95	124,76	-63	72	135	109	100	45	172	170	190	195	100	90
CHV050.75	75°	165,42	134,11	-68	67	135	109	100	45	172	170	190	195	100	90





AERIAL CAM UNIT - OBEN HÄNGENDER SCHIEBER - UNITÀ A CAMME SOSPESA

X VIEW

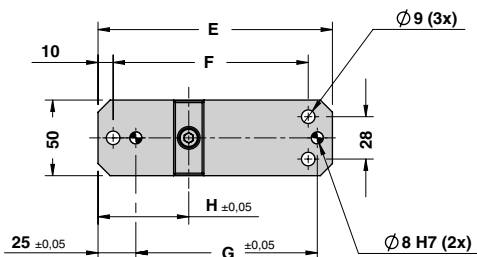
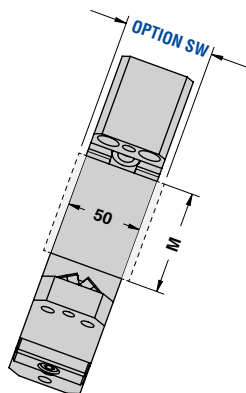

CAM DIAGRAM

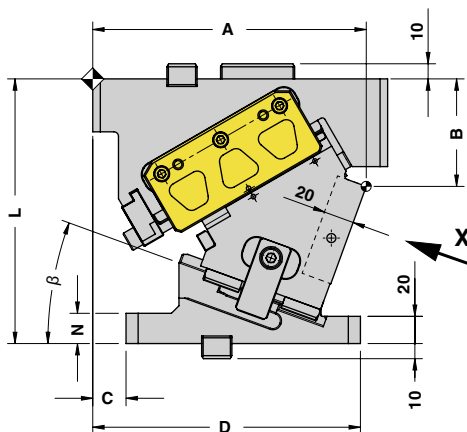
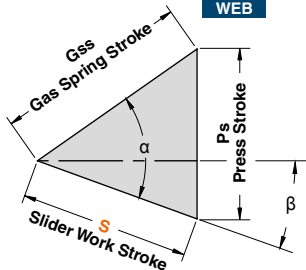

Work Angle	Inner Angle	Slider Work Stroke (mm)	Press Stroke (mm)	Gas Spring Stroke (mm)
$\beta$	$\alpha$	S	Ps	Gss

0°	50°	28,93	34,47	45
5°	50°	31,94	34,60	45
10°	50°	35,00	35,00	45
15°	50°	38,16	35,69	45
20°	50°	41,47	36,68	45
25°	50°	45,00	38,04	45
30°	50°	48,83	39,80	45
35°	50°	53,06	42,08	45
40°	50°	57,85	45,00	45
45°	50°	63,40	48,75	45
50°	50°	62,23	47,67	40
55°	55°	59,28	48,56	34
60°	60°	60,00	51,96	30
65°	65°	59,16	53,61	25
70°	70°	58,48	54,95	20
75°	75°	57,96	55,98	15

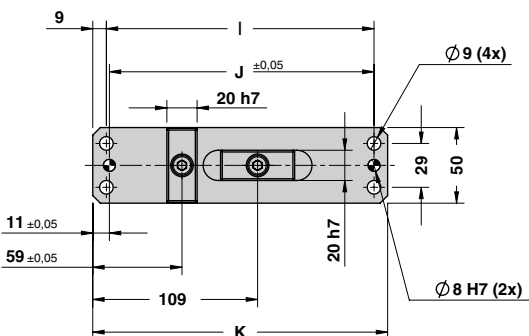

Cam Units CHV



AERIAL CAM UNIT - OBEN HÄNGENDER SCHIEBER - UNITÀ A CAMME SOSPESA

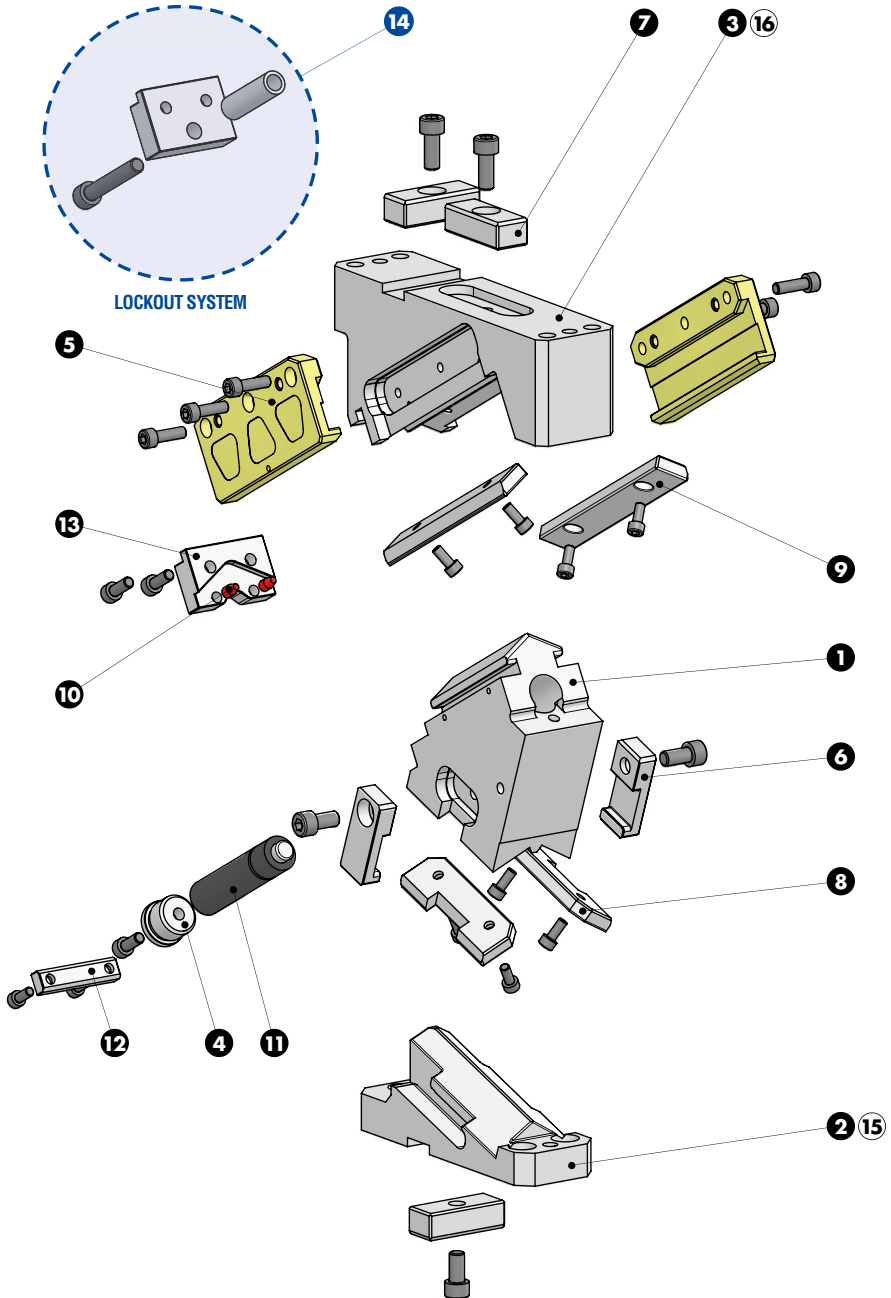



**AERIAL CAM UNIT - OBEN HÄNGENDER SCHIEBER - UNITÀ A CAMME SOSPESA**

SLIDER STRUCTURE, POSITIVE RETURN STRUCTURE AND CLEARANCES

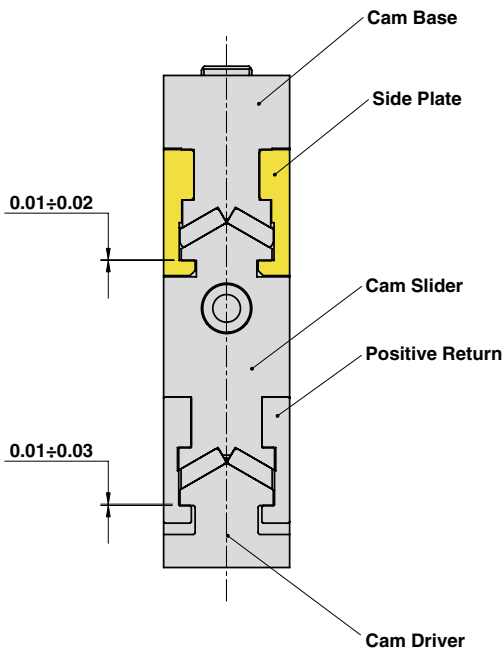

PART LIST

Particular number	Description	Material	Quantity
1	Cam Slider	42CrMo4	1
2	Cam Driver	42CrMo4	1
3	Cam Base	42CrMo4	1
4	Spring spacer	CK45	1
5	Side plate	CuZn25Al5 + Graphite - HB > 190	2
6	Positive Return	42CrMo4 Nitrided	2
7	Key	CK45	3
8	Wear Plate	St42 + Syntered layer	2
9	Wear Plate	St42 + Syntered layer	2
10	Elastomer Cap	Elastomer 92SH	2
11	Gas Spring	-	1
12	Safety plate	CK45	1
13	Stopper plate	CK45	1
14	LOCKOUT SYSTEM	(more info on OMCR website)	1
15	Cam Driver Fixing Screws M8x25 DIN 912 Cl. 12.9	-	3
16	Cam Base Fixing Screws M8x30 DIN 912 Cl. 12.9	-	4

Cam Units CHV



## AERIAL CAM UNIT - OBEN HÄNGENDER SCHIEBER - UNITÀ A CAMME SOSPESA

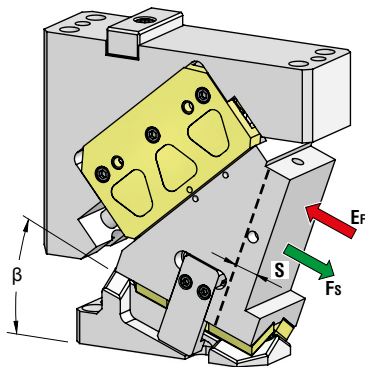

OMCR CODE	Work Angle	Stroke (mm)	Max Work Force with shoulder (kN)	Extraction Force (kN)
	$\beta$	S	F <sub>s</sub>	E <sub>F</sub> Gas Spring
CHV060.00	0°	19,28	136	5,1
CHV060.05	5°	21,29	137	5,1
CHV060.10	10°	21,54	138	5,4
CHV060.15	15°	23,79	139	5,4
CHV060.20	20°	24,46	140	5,7
CHV060.25	25°	27,12	141	5,7
CHV060.30	30°	30	142	5,7
CHV060.35	35°	31,72	143	5,9
CHV060.40	40°	35,49	143	5,9
CHV060.45	45°	38,45	143	6,0
CHV060.50	50°	43,86	142	6,0
CHV060.55	55°	49,15	142	6,1
CHV060.60	60°	57,96	142	6,1
CHV060.65	65°	68,57	142	6,2
CHV060.70	70°	70,60	141	6,2
CHV060.75	75°	76,10	141	6,2

15



Art.	Work Angle = 5°
CHV060	05

OMCR CODE	Work Angle	Overall Dimensions (mm)										
	$\beta$	A	B	C	D	E	F	G	H	I	J	K
CHV060.00	0°	175	55	25	180	155	105	120	180	175	62,5	205
CHV060.05	5°	179,26	57,37	25	175	150	105	120	180	175	62,5	205
CHV060.10	10°	183,30	60,10	25	170	145	105	120	180	175	62,5	205
CHV060.15	15°	189,68	63,51	25	165	140	105	120	180	175	62,5	205
CHV060.20	20°	190,59	76,57	25	165	140	105	120	180	175	62,5	205
CHV060.25	25°	193,79	80,25	25	150	125	80	95	180	175	62,5	205
CHV060.30	30°	196,65	84,20	25	150	125	80	95	180	175	62,5	205
CHV060.35	35°	199,16	88,38	25	140	115	80	95	180	175	62,5	205
CHV060.40	40°	198,08	96,60	10	120	110	65	80	195	190	62,5	220
CHV060.45	45°	225,96	104,39	40	145	105	65	80	210	205	92,5	235
CHV060.50	50°	211,71	113,44	10	115	105	50	65	195	190	77,5	220
CHV060.55	55°	212,11	117,54	10	115	105	50	70	195	190	77,5	220
CHV060.60	60°	203,48	126,65	10	102	92	50	65	195	190	77,5	220
CHV060.65	65°	202,75	129,98	10	95	85	50	65	195	190	77,5	220
CHV060.70	70°	205,54	146,39	10	95	85	20	35	195	190	62,5	220
CHV060.75	75°	204,77	151,21	10	90	80	20	35	210	205	62,5	235



AERIAL CAM UNIT - OBEN HÄNGENDER SCHIEBER - UNITÀ A CAMME SOSPESA

X VIEW

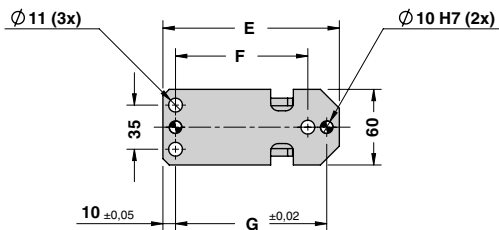
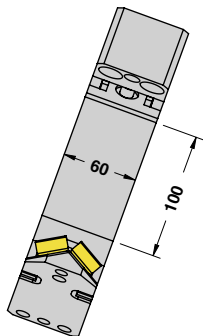

CAM DIAGRAM

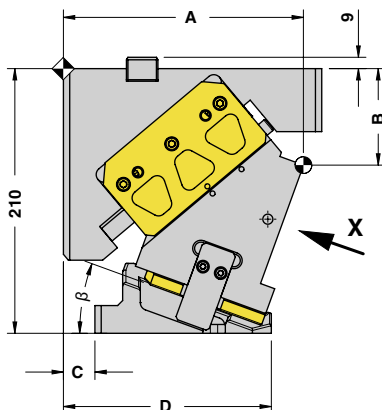
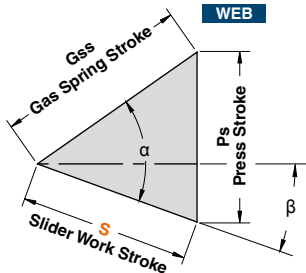

Work Angle	Inner Angle	Slider Work Stroke (mm)	Press Stroke (mm)	Gas Spring Stroke (mm)
$\beta$	$\alpha$	S	Ps	Gss

0°	50°	19,28	22,98	30
5°	50°	21,29	23,07	30
10°	55°	21,54	24,95	30
15°	55°	23,79	25,44	30
20°	60°	24,46	27,65	30
25°	60°	27,12	28,67	30
30°	60°	30,00	30,00	30
35°	65°	31,72	33,19	30
40°	65°	35,49	35,49	30
45°	70°	38,45	39,87	30
50°	70°	43,86	43,86	30
55°	75°	49,15	50,52	30
60°	75°	57,96	57,96	30
65°	80°	68,57	69,91	30
70°	85°	70,60	72,82	25
75°	85°	76,10	76,98	20

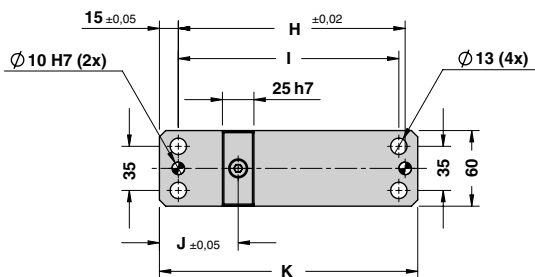

Cam Units CHV





AERIAL CAM UNIT - OBEN HÄNGENDER SCHIEBER - UNITÀ A CAMME SOSPESA

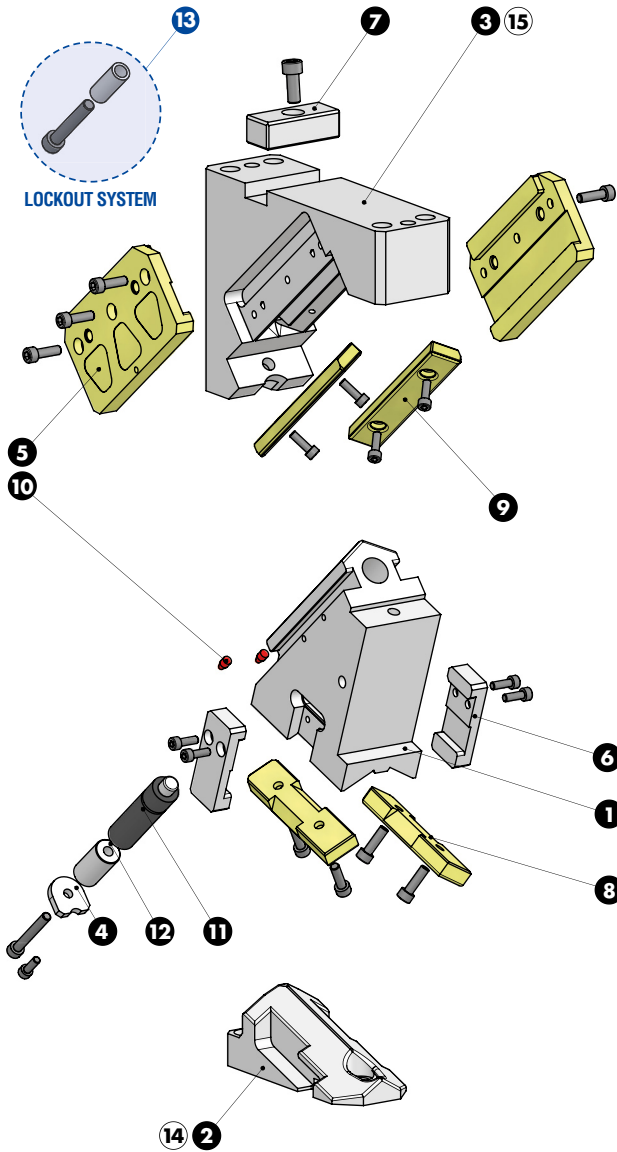



**AERIAL CAM UNIT - OBEN HÄNGENDER SCHIEBER - UNITÀ A CAMME SOSPESA**

SLIDER STRUCTURE, POSITIVE RETURN STRUCTURE AND CLEARANCES

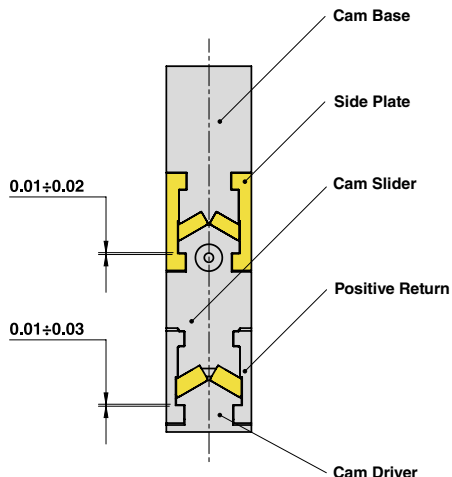

PART LIST

Particular number	Description	Material	Quantity
1	Cam Slider	42CrMo4	1
2	Cam Driver	42CrMo4	1
3	Cam Base	42CrMo4	1
4	Lock Plate	42CrMo4	1
5	Side Plate	CuZn25Al5 + Graphite - HB > 190	2
6	Positive Return	42CrMo4 Nitrided	2
7	Key	CK45	1
8	Wear Plate	CuZn25Al5 + Graphite - HB > 190	2
9	Wear Plate	CuZn25Al5 + Graphite - HB > 190	2
10	Elastomer Cap	Elastomer 92SH	2
11	Gas Spring	-	1
12	Spring Spacer	CK45	1
13	<b>LOCKOUT SYSTEM</b>	(more info on OMCR website)	1
14	Cam Driver Fixing Screws M10x30 DIN 912	-	3
15	Cam Base Fixing Screws M12x60 DIN 912	-	4



## AERIAL CAM UNIT - OBEN HÄNGENDER SCHIEBER - UNITÀ A CAMME SOSPESA

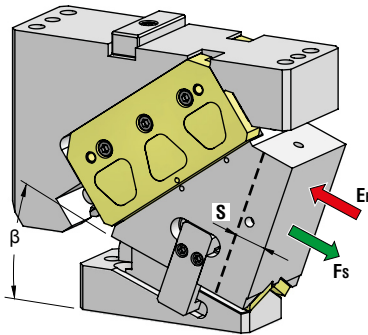

OMCR CODE	Work Angle	Stroke (mm)	Max Work Force with shoulder (kN)	Extraction Force (kN)
	$\beta$	S	F <sub>s</sub>	E <sub>F</sub> Gas Spring
CHV085.00	0°	30,85	230	10,0
CHV085.05	5°	34,07	230	10,0
CHV085.10	10°	34,46	230	10,5
CHV085.15	15°	38,07	230	10,5
CHV085.20	20°	41,84	230	10,5
CHV085.25	25°	43,38	229	11,0
CHV085.30	30°	48	229	11,0
CHV085.35	35°	50,75	229	11,4
CHV085.40	40°	56,79	237	11,4
CHV085.45	45°	42,30	245	11,5
CHV085.50	50°	48,24	253	11,5
CHV085.55	55°	54,06	261	11,8
CHV085.60	60°	63,75	269	11,8
CHV085.65	65°	75,42	277	11,9
CHV085.70	70°	95,02	285	11,9
CHV085.75	75°	95,13	293	12,0

15



Art.	Work Angle = 5°
CHV085	05

OMCR CODE	Work Angle	Overall Dimensions (mm)											
	$\beta$	A	B	C	D	E	F	G	H	I	J	K	L
CHV085.00	0°	238	60	55	230	175	35	90	25	130	225	82	255
CHV085.05	5°	243,28	64,18	55	225	170	35	90	25	130	225	88	255
CHV085.10	10°	247,73	73,75	55	215	160	35	90	25	130	225	88	255
CHV085.15	15°	252,64	78,77	55	210	155	35	90	25	130	225	97	255
CHV085.20	20°	259,24	79,51	55	210	155	35	90	25	130	225	103	255
CHV085.25	25°	262,37	90,08	40	195	155	35	90	25	130	255	103	285
CHV085.30	30°	272,11	87,71	40	195	155	35	90	25	130	255	112	285
CHV085.35	35°	277,45	94,87	40	195	155	35	90	25	130	255	112	285
CHV085.40	40°	282,59	102,49	40	195	155	35	90	25	130	255	122,5	285
CHV085.45	45°	245,4	117,6	0	150	150	35	70	25	110	235	92	265
CHV085.50	50°	247,12	127,38	0	135	135	35	70	25	110	235	96,5	265
CHV085.55	55°	263	126,74	0	135	135	35	70	25	110	235	96,5	265
CHV085.60	60°	267,02	136,11	0	135	135	35	70	25	110	235	104	265
CHV085.65	65°	257,06	147,15	0	126	126	35	60	25	100	235	104	265
CHV085.70	70°	248,86	160,81	5	114	109	15	40	35	60	245	82,5	275
CHV085.75	75°	251,61	181,07	5	114	109	15	40	35	60	245	82,5	275



AERIAL CAM UNIT - OBEN HÄNGENDER SCHIEBER - UNITÀ A CAMME SOSPESA

X VIEW

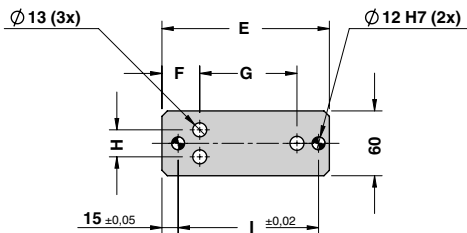
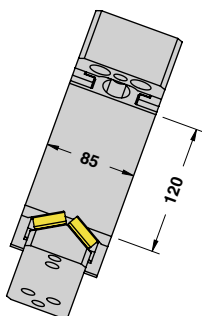

CAM DIAGRAM

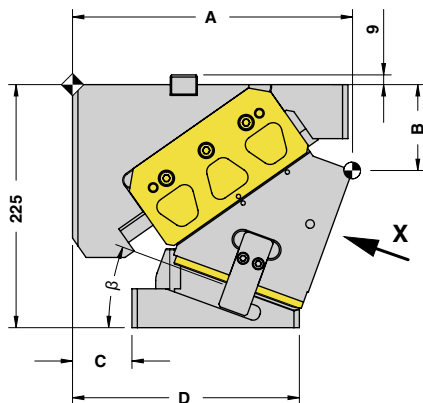
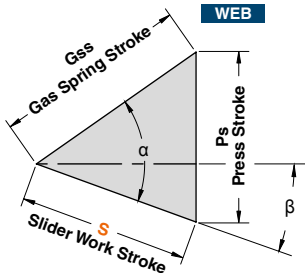

Work Angle	Inner Angle	Slider Work Stroke (mm)	Press Stroke (mm)	Gas Spring Stroke (mm)
$\beta$	$\alpha$	S	Ps	Gss

0°	50°	30,85	36,77	48
5°	50°	34,07	36,91	48
10°	55°	34,46	39,93	48
15°	55°	38,07	40,71	48
20°	55°	41,84	41,84	48
25°	60°	43,38	45,87	48
30°	60°	48,00	48,00	48
35°	65°	50,75	53,11	48
40°	65°	56,79	56,79	48
45°	70°	42,30	43,85	33
50°	70°	48,24	48,24	33
55°	75°	54,06	55,57	33
60°	75°	63,75	63,75	33
65°	80°	75,42	76,90	33
70°	80°	95,02	95,02	33
75°	85°	95,13	96,23	25

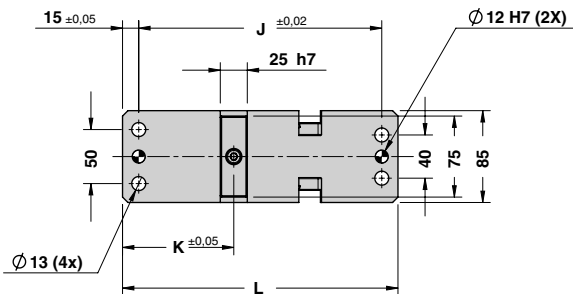

Cam Units CHV



AERIAL CAM UNIT - OBEN HÄNGENDER SCHIEBER - UNITÀ A CAMME SOSPESA

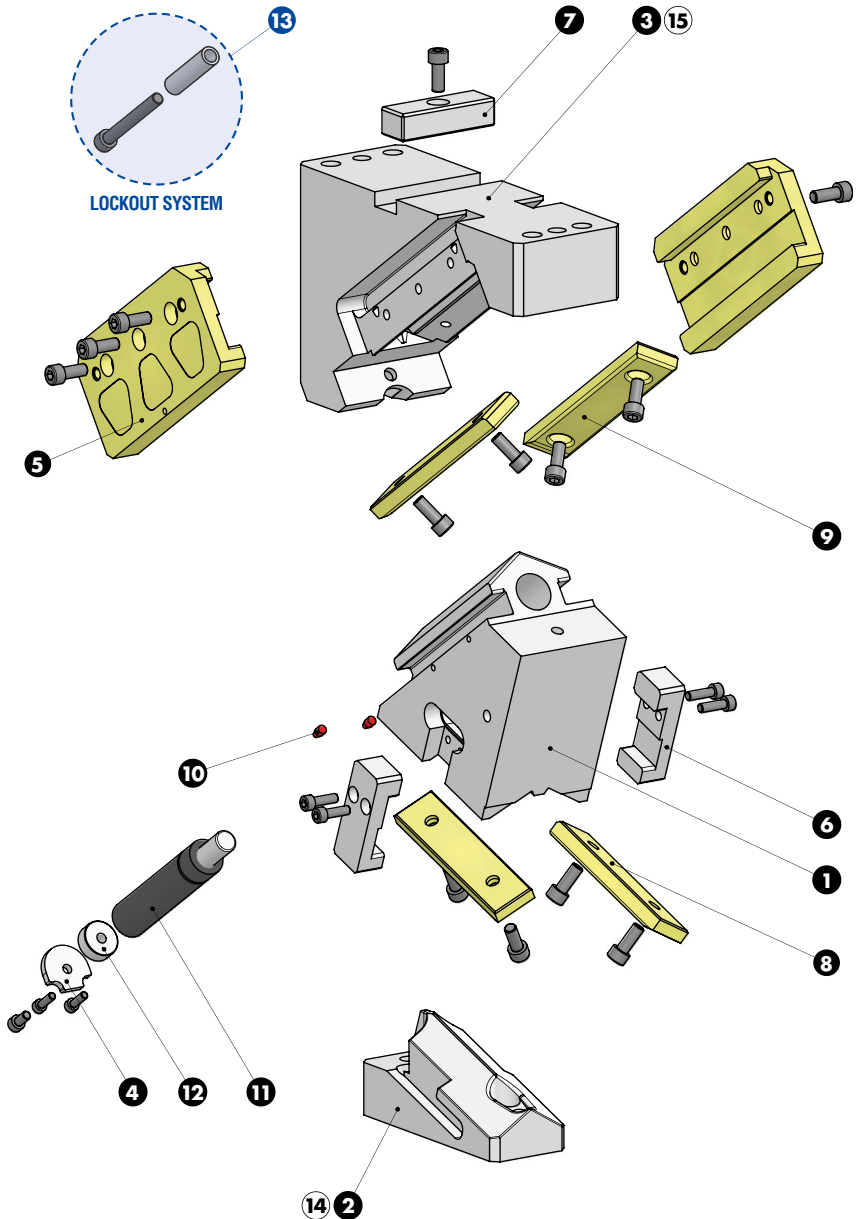



**AERIAL CAM UNIT - OBEN HÄNGENDER SCHIEBER - UNITÀ A CAMME SOSPESA**

SLIDER STRUCTURE, POSITIVE RETURN STRUCTURE AND CLEARANCES

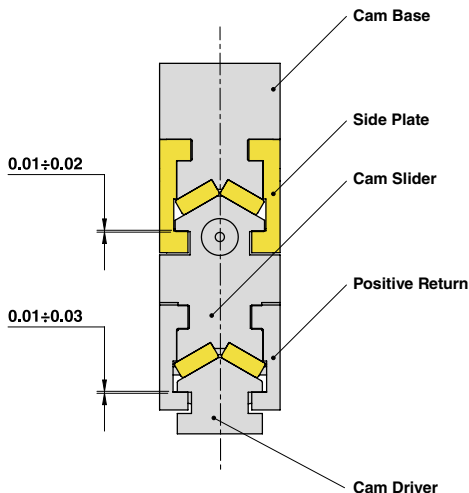

PART LIST

Particular number	Description	Material	Quantity
1	Cam Slider	42CrMo4	1
2	Cam Driver	42CrMo4	1
3	Cam Base	42CrMo4	1
4	Lock Plate	42CrMo4	1
5	Side Plate	CuZn25Al5 + Graphite - HB > 190	2
6	Positive Return	42CrMo4 Nitrided	2
7	Key	CK45	1
8	Wear Plate VDI 3357	CuZn25Al5 + Graphite - HB > 190	2
9	Wear Plate VDI 3357	CuZn25Al5 + Graphite - HB > 190	2
10	Elastomer Cap	Elastomer 92SH	2
11	Gas Spring	-	1
12	Spring Spacer	CK45	1
13	LOCKOUT SYSTEM	(more info on OMCR website)	1
14	Cam Driver Fixing Screws M12x35 DIN 912	-	3
15	Cam Base Fixing Screws M12x65 DIN 912	-	4



## AERIAL CAM UNIT - OBEN HÄNGENDER SCHIEBER - UNITÀ A CAMME SOSPESA

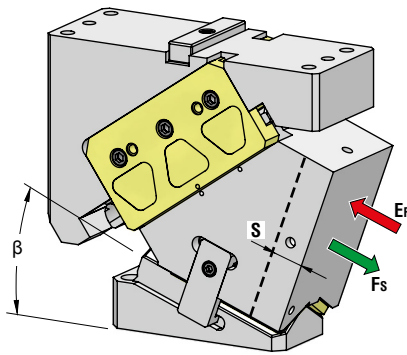

OMCR CODE	Work Angle	Stroke (mm)	Max Work Force with shoulder (kN)	Extraction Force (kN)
	$\beta$	S	Fs	Ef Gas Spring
CHV110.00	0°	30,85	357	11,4
CHV110.05	5°	34,07	366	11,4
CHV110.10	10°	34,46	369	12,2
CHV110.15	15°	38,07	372	12,2
CHV110.20	20°	41,84	375	12,2
CHV110.25	25°	43,38	378	12,8
CHV110.30	30°	48	381	12,8
CHV110.35	35°	50,75	384	13,4
CHV110.40	40°	56,79	387	13,4
CHV110.45	45°	61,52	390	13,6
CHV110.50	50°	48,24	393	13,6
CHV110.55	55°	54,06	396	13,6
CHV110.60	60°	63,75	399	14,0
CHV110.65	65°	75,42	402	14,3
CHV110.70	70°	95,02	405	14,4
CHV110.75	75°	95,13	407	14,4



Art.	Work Angle = 5°
CHV110	05

OMCR CODE	Work Angle	Overall Dimensions (mm)												
		$\beta$	A	B	C	D	E	F	G	H	I	J	K	L
CHV110.00	0°	278	70	60	270	210	85	35	15	155	15	255	97,5	290
CHV110.05	5°	285,45	74,28	60	265	205	85	35	15	155	15	255	117	290
CHV110.10	10°	292,94	79,21	60	255	195	85	35	15	155	15	255	124,5	290
CHV110.15	15°	300,41	84,79	60	250	190	85	35	15	155	15	255	133,5	290
CHV110.20	20°	307,80	91,02	60	245	185	85	35	15	155	15	255	141	290
CHV110.25	25°	302,93	102,42	50	228	178	40	45	15	135	20	260	140	300
CHV110.30	30°	309,61	109,72	50	222	172	40	45	15	135	20	260	147,5	300
CHV110.35	35°	316,06	117,58	50	217	167	40	45	15	135	20	260	155	300
CHV110.40	40°	322,23	126	50	213	163	40	45	15	135	20	260	162,5	300
CHV110.45	45°	311,62	131,41	10	193	183	55	45	20	120	15	265	148,5	295
CHV110.50	50°	309,74	147,60	10	182	172	55	45	20	120	15	265	154,5	295
CHV110.55	55°	302,27	165,76	10	167	157	55	45	20	120	15	265	175,5	295
CHV110.60	60°	305,96	174,61	10	165	155	55	45	20	120	15	265	175,5	295
CHV110.65	65°	285,71	195,11	0	137	137	55	25	20	100	15	265	155,5	295
CHV110.70	70°	288,18	208,33	0	135	135	55	25	20	100	15	265	155,5	295
CHV110.75	75°	290,36	211,76	0	134	134	55	25	20	100	15	275	155,5	310





## AERIAL CAM UNIT - OBEN HÄNGENDER SCHIEBER - UNITÀ A CAMME SOSPESA

### X VIEW

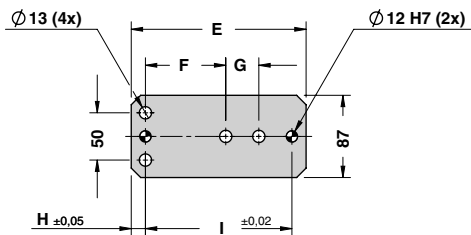
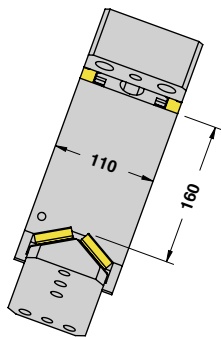

### CAM DIAGRAM

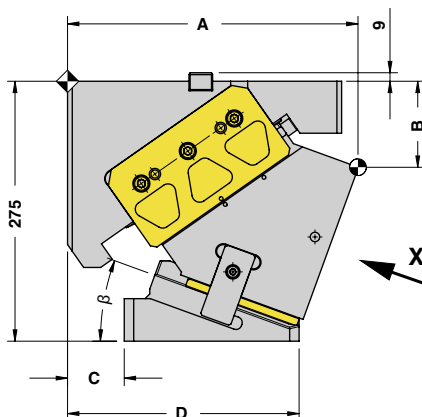
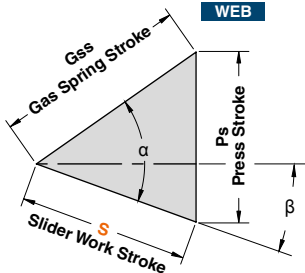

Work Angle	Inner Angle	Slider Work Stroke (mm)	Press Stroke (mm)	Gas Spring Stroke (mm)
$\beta$	$\alpha$	S	Ps	Gss

0°	50°	30,85	36,77	48
5°	50°	34,07	36,91	48
10°	55°	34,46	39,93	48
15°	55°	38,07	40,71	48
20°	55°	41,84	41,84	48
25°	60°	43,38	45,87	48
30°	60°	48,00	48,00	48
35°	65°	50,75	53,11	48
40°	65°	56,79	56,79	48
45°	70°	61,52	63,79	48
50°	70°	48,24	48,24	33
55°	75°	54,06	55,57	33
60°	75°	63,75	63,75	33
65°	80°	75,42	76,90	33
70°	80°	95,02	95,02	33
75°	85°	95,13	96,23	25

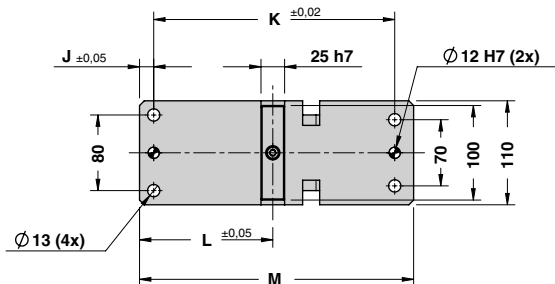





## AERIAL CAM UNIT - OBEN HÄNGENDER SCHIEBER - UNITÀ A CAMME SOSPESA

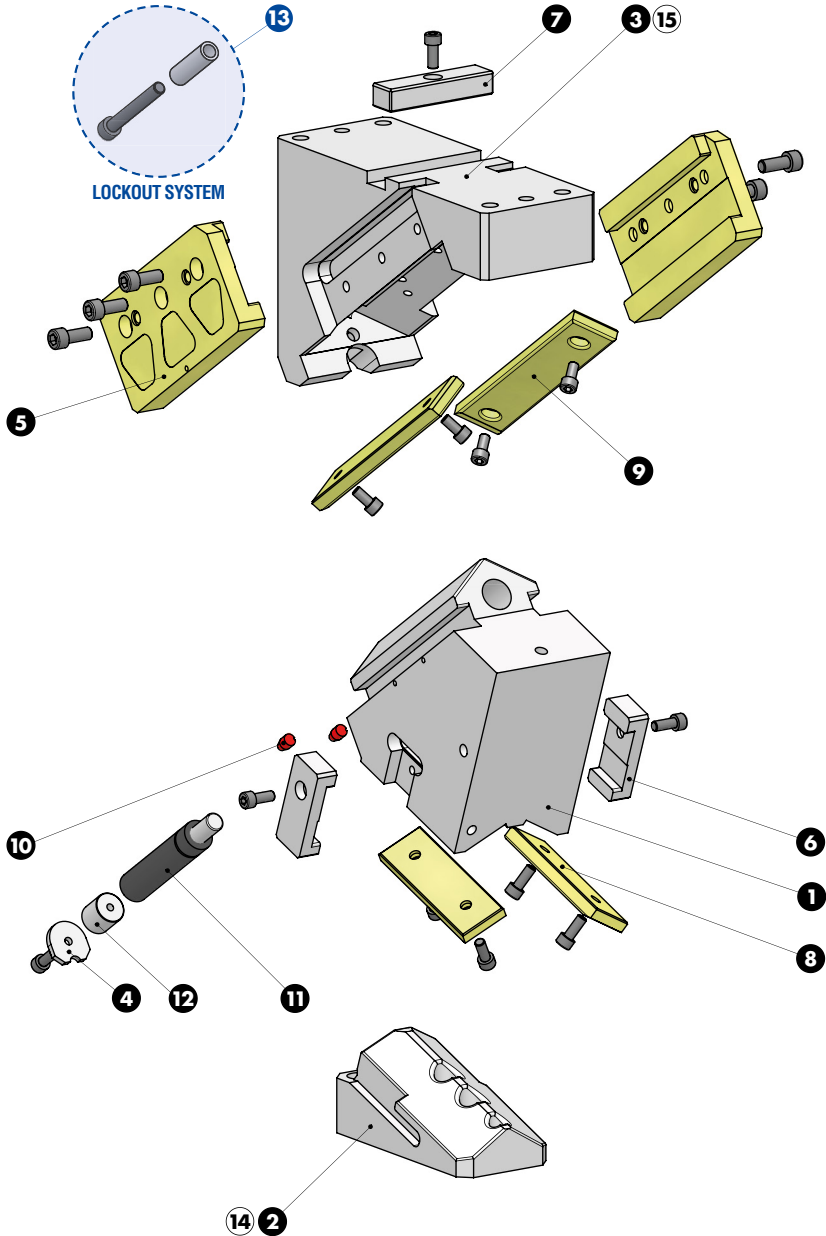



AERIAL CAM UNIT - OBEN HÄNGENDER SCHIEBER - UNITÀ A CAMME SOSPESA

SLIDER STRUCTURE, POSITIVE RETURN STRUCTURE AND CLEARANCES

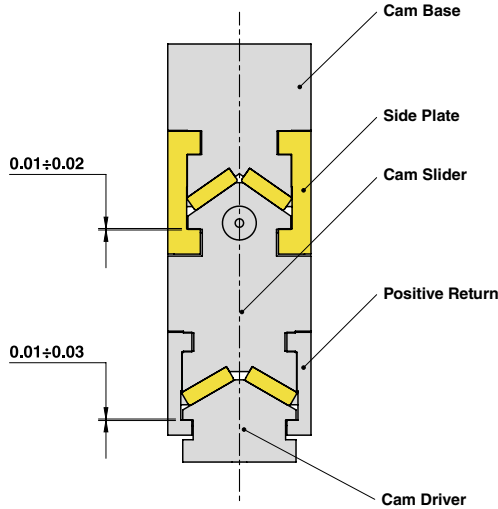

Cam Units CHV

PART LIST

Particular number	Description	Material	Quantity
1	Cam Slider	42CrMo4	1
2	Cam Driver	42CrMo4	1
3	Cam Base	42CrMo4	1
4	Lock Plate	42CrMo4	1
5	Side Plate	CuZn25Al5 + Graphite - HB > 190	2
6	Positive Return	42CrMo4 Nitrided	2
7	Key	CK45	1
8	Wear Plate VDI 3357	CuZn25Al5 + Graphite - HB > 190	2
9	Wear Plate VDI 3357	CuZn25Al5 + Graphite - HB > 190	2
10	Elastomer Cap	Elastomer 92SH	2
11	Gas Spring	-	1
12	Spring Spacer	CK45	1
13	LOCKOUT SYSTEM	(more info on OMCR website)	1
14	Cam Driver Fixing Screws M12x45 DIN 912	-	4
15	Cam Base Fixing Screws M12x65 DIN 912	-	4



## AERIAL CAM UNIT - OBEN HÄNGENDER SCHIEBER - UNITÀ A CAMME SOSPESA

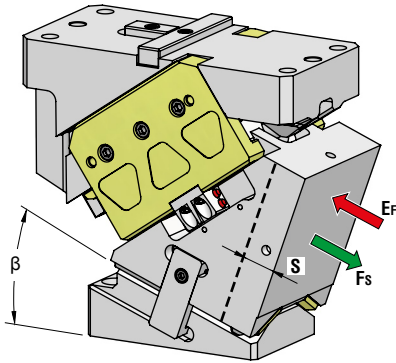

OMCR CODE	Work Angle	Stroke (mm)	Max Work Force with shoulder (kN)	Extraction Force (kN)
	$\beta$	S	$F_s$	$E_f$ Gas Spring
CHV150.00	0°	32,14	421	16,4
CHV150.05	5°	35,49	435	16,4
CHV150.10	10°	35,90	448	17,5
CHV150.15	15°	39,65	462	17,5
CHV150.20	20°	43,59	476	17,5
CHV150.25	25°	45,19	489	18,4
CHV150.30	30°	50	503	18,4
CHV150.35	35°	52,86	517	19,2
CHV150.40	40°	59,16	528	19,2
CHV150.45	45°	64,09	540	19,8
CHV150.50	50°	73,10	551	19,8
CHV150.55	55°	81,92	558	20,3
CHV150.60	60°	96,59	565	20,3
CHV150.65	65°	91,42	571	20,5
CHV150.70	70°	84,73	578	20,7
CHV150.75	75°	76,10	584	20,6

15



Art.	Work Angle = 5°
CHV150	05

OMCR CODE	Work Angle	Overall Dimensions (mm)											
		$\beta$	A	B	C	D	E	F	G	H	I	J	K
CHV150.00	0°	298	65	70	290	220	85	150	25	270	54	117	310
CHV150.05	5°	307,20	69,35	70	280	210	85	150	25	270	61,5	124,5	310
CHV150.10	10°	313,81	89,28	70	270	200	85	150	25	270	69	132	310
CHV150.15	15°	321,70	94,96	70	265	195	85	150	25	270	78	141	310
CHV150.20	20°	329,51	101,32	70	264	194	85	150	25	270	85,5	148,5	310
CHV150.25	25°	342,93	117,42	60	262	202	105	170	15	320	104,5	167,5	350
CHV150.30	30°	352,11	125,39	60	259	199	105	170	15	320	112	175	350
CHV150.35	35°	364,66	130,30	60	261	201	105	170	15	320	119,5	182,5	350
CHV150.40	40°	371,87	144,51	60	257	197	105	170	15	320	127	190	350
CHV150.45	45°	325,76	152,27	20	202	182	85	150	15	310	73	136	340
CHV150.50	50°	332,72	168,31	20	199	179	85	150	15	310	79	142	340
CHV150.55	55°	347,32	179,21	20	206	186	85	150	15	310	64,5	127,5	340
CHV150.60	60°	353,59	197,11	20	203	183	85	150	15	310	71,5	134,5	340
CHV150.65	65°	359,15	205,52	20	203	183	85	150	15	310	71,5	134,5	340
CHV150.70	70°	334,26	226,10	0	168	168	70	135	15	310	71,5	134,5	340
CHV150.75	75°	338,15	234,94	0	167	167	70	135	15	310	71,5	134,5	340



AERIAL CAM UNIT - OBEN HÄNGENDER SCHIEBER - UNITÀ A CAMME SOSPESA

X VIEW

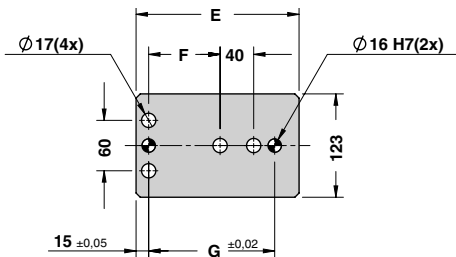
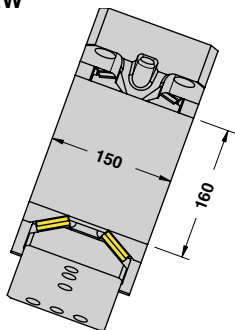

CAM DIAGRAM

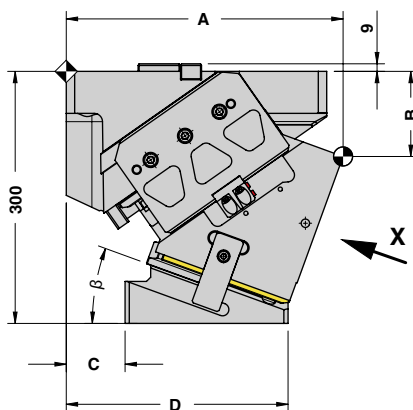
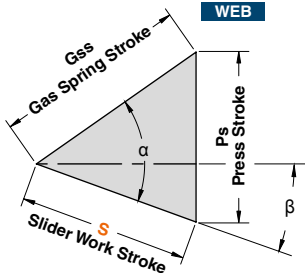

Work Angle	Inner Angle	Slider Work Stroke (mm)	Press Stroke (mm)	Gas Spring Stroke (mm)
$\beta$	$\alpha$	S	Ps	Gss

0°	50°	32,14	38,30	50
5°	50°	35,49	38,45	50
10°	55°	35,90	41,59	50
15°	55°	39,65	42,40	50
20°	55°	43,59	43,59	50
25°	60°	45,19	47,78	50
30°	60°	50,00	50,00	50
35°	65°	52,86	55,32	50
40°	65°	59,16	59,16	50
45°	70°	64,09	66,45	50
50°	70°	73,10	73,10	50
55°	75°	81,92	84,20	50
60°	75°	96,59	96,59	50
65°	80°	91,42	93,21	40
70°	85°	84,73	87,38	30
75°	85°	76,10	76,98	20

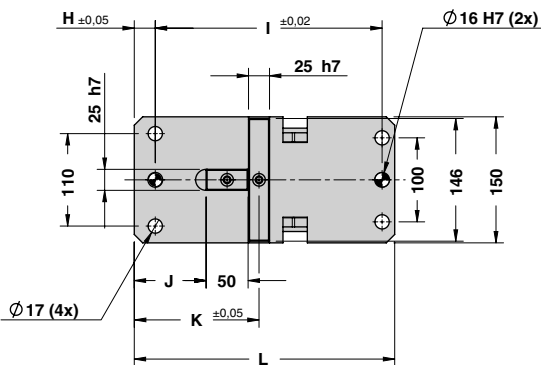

Cam Units CHV



## AERIAL CAM UNIT - OBEN HÄNGENDER SCHIEBER - UNITÀ A CAMME SOSPESA

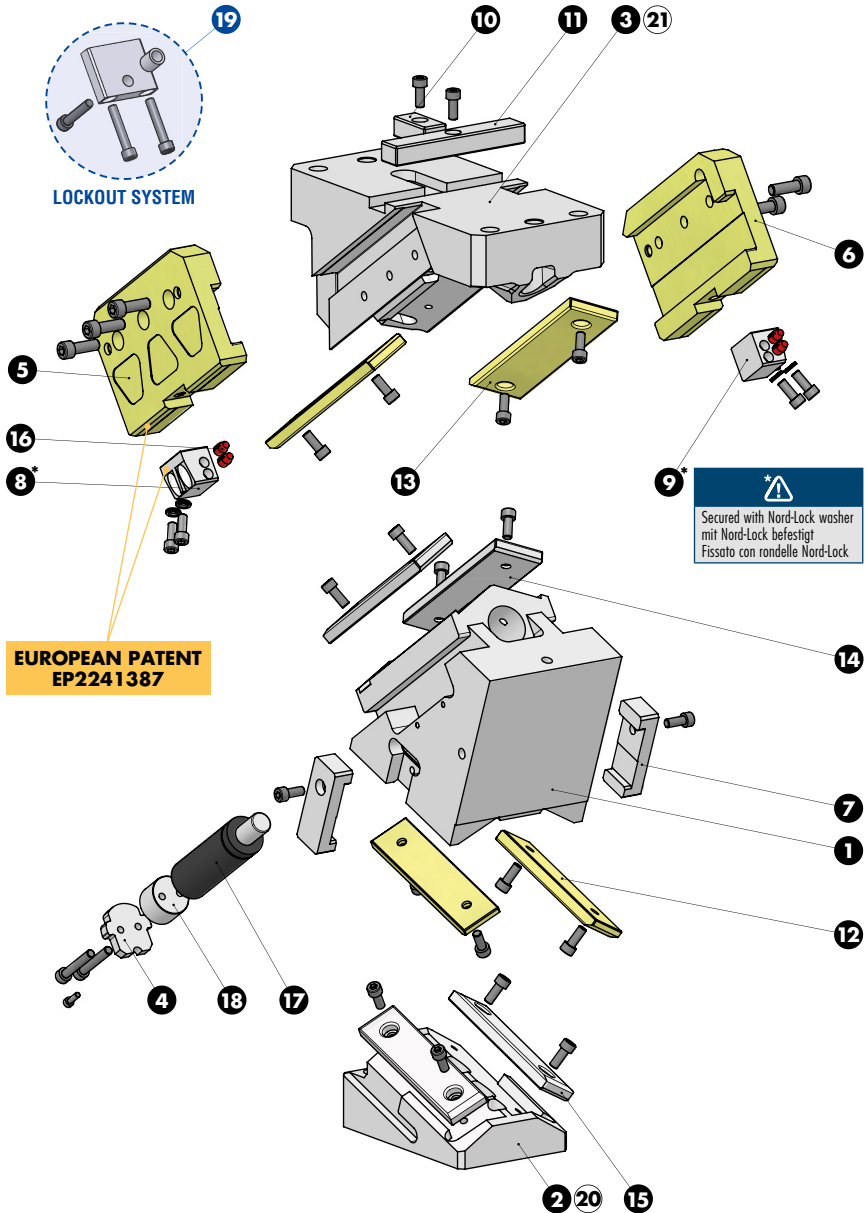



**AERIAL CAM UNIT - OBEN HÄNGENDER SCHIEBER - UNITÀ A CAMME SOSPESA**

**SLIDER STRUCTURE, POSITIVE RETURN STRUCTURE AND CLEARANCES**

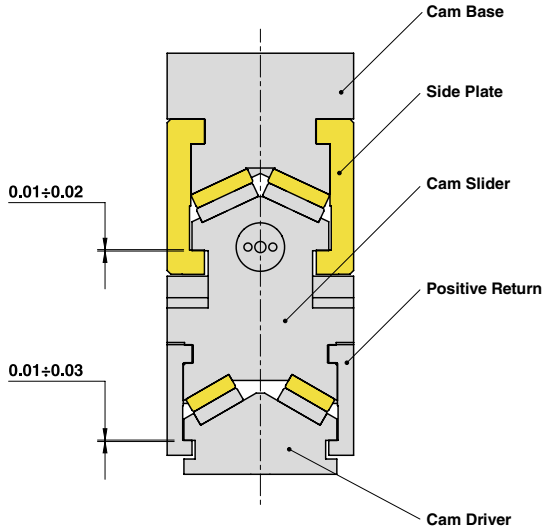

Cam Units CHV

**PART LIST**

Particular number	Description	Material	Quantity
1	Cam Slider	GGG-60	1
2	Cam Driver	GGG-60	1
3	Cam Base	GGG-60	1
4	Lock Plate	42CrMo4	1
5	Side Plate L	CuZn25Al5 + Graphite - HB > 190	1
6	Side Plate R	CuZn25Al5 + Graphite - HB > 190	1
7	Positive Return	42CrMo4 Nitrided	2
8	Slide Reaction L	CK45	1
9	Slide Reaction R	CK45	1
10	Key	CK45	1
11	Key	CK45	1
12	Wear Plate VDI 3357	CuZn25Al5 + Graphite - HB > 190	2
13	Wear Plate VDI 3357	CuZn25Al5 + Graphite - HB > 190	2
14	Wear Plate VDI 3357	16MnCr5 - HRC 58-60	2
15	Wear Plate VDI 3357	16MnCr5 - HRC 58-60	2
16	Elastomer Cap	Elastomer 92SH	4
17	Gas Spring	-	1
18	Gas Spring Spacer	CK45	1
19	<b>LOCKOUT SYSTEM</b>	(more info on OMCR website)	1
20	Cam Driver Fixing Screws M16x55 DIN 912	-	4
21	Cam Base Fixing Screws M16x65 DIN 912	-	4



## AERIAL CAM UNIT - OBEN HÄNGENDER SCHIEBER - UNITÀ A CAMME SOSPESA

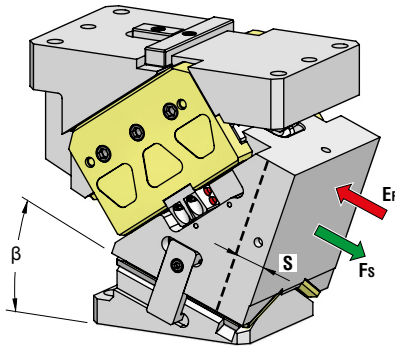

OMCR CODE	Work Angle	Stroke (mm)	Max Work Force with shoulder (kN)	Extraction Force (kN)
	$\beta$	S	$F_s$	$E_f$ Gas Spring
CHV180.00	0°	32,14	474	16,2
CHV180.05	5°	35,49	488	16,2
CHV180.10	10°	35,90	503	17,3
CHV180.15	15°	39,65	518	17,3
CHV180.20	20°	43,59	533	17,3
CHV180.25	25°	45,19	542	18,2
CHV180.30	30°	50	543	18,2
CHV180.35	35°	52,86	543	18,9
CHV180.40	40°	59,16	550	18,9
CHV180.45	45°	64,09	557	19,5
CHV180.50	50°	73,10	564	19,5
CHV180.55	55°	81,92	571	20,0
CHV180.60	60°	96,59	578	20,0
CHV180.65	65°	91,42	584	20,2
CHV180.70	70°	84,73	591	20,4
CHV180.75	75°	76,10	598	20,3

15



Art.	Work Angle = 5°
CHV180	05

OMCR CODE	Work Angle	Overall Dimensions (mm)											
	$\beta$	A	B	C	D	E	F	G	H	I	J	K	L
CHV180.00	0°	298	65	70	290	220	85	150	25	270	54	117	310
CHV180.05	5°	307,20	69,35	70	280	210	85	150	25	270	61,5	124,5	310
CHV180.10	10°	313,81	89,28	70	270	200	85	150	25	270	69	132	310
CHV180.15	15°	321,70	94,96	70	265	195	85	150	25	270	78	141	310
CHV180.20	20°	329,51	101,32	70	261	191	85	150	25	270	85,5	148,5	310
CHV180.25	25°	342,93	117,42	60	259	199	105	170	15	320	104,5	167,5	350
CHV180.30	30°	352,11	125,39	60	259	199	105	170	15	320	112	175	350
CHV180.35	35°	364,66	130,30	60	261	201	105	170	15	320	119,5	182,5	350
CHV180.40	40°	371,87	144,51	60	257	197	105	170	15	320	127	190	350
CHV180.45	45°	325,76	152,27	20	202	182	85	150	15	310	73	136	340
CHV180.50	50°	332,72	168,31	20	199	179	85	150	15	310	79	142	340
CHV180.55	55°	347,32	179,21	20	206	186	85	150	15	310	64,5	127,5	340
CHV180.60	60°	353,59	197,11	20	202	182	85	150	15	310	71,5	134,5	340
CHV180.65	65°	359,15	205,52	20	201	181	85	150	15	310	71,5	134,5	340
CHV180.70	70°	334,26	226,10	0	168	168	70	135	15	310	71,5	134,5	340
CHV180.75	75°	338,15	234,94	0	172	172	70	135	15	310	71,5	134,5	340



AERIAL CAM UNIT - OBEN HÄNGENDER SCHIEBER - UNITÀ A CAMME SOSPESA

X VIEW

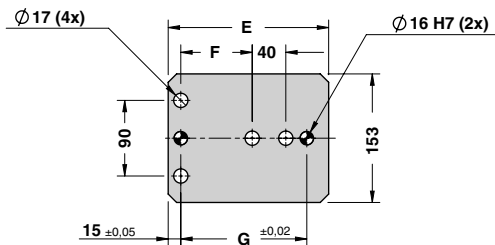
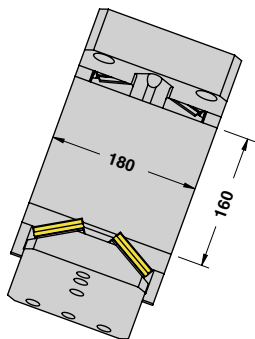

CAM DIAGRAM

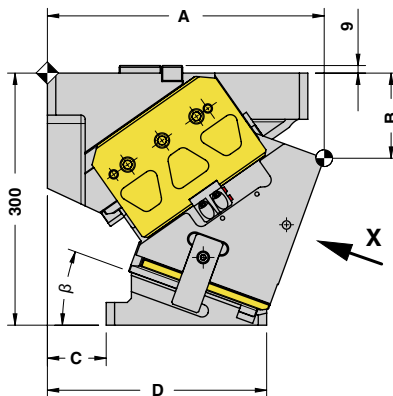
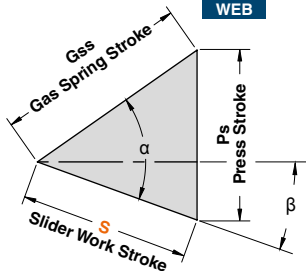

Work Angle	Inner Angle	Slider Work Stroke (mm)	Press Stroke (mm)	Gas Spring Stroke (mm)
$\beta$	$\alpha$	S	Ps	Gss

0°	50°	32,14	38,30	50
5°	50°	35,49	38,45	50
10°	55°	35,90	41,59	50
15°	55°	39,65	42,40	50
20°	55°	43,59	43,59	50
25°	60°	45,19	47,78	50
30°	60°	50,00	50,00	50
35°	65°	52,86	55,32	50
40°	65°	59,16	59,16	50
45°	70°	64,09	66,45	50
50°	70°	73,10	73,10	50
55°	75°	81,92	84,20	50
60°	75°	96,59	96,59	50
65°	80°	91,42	93,21	40
70°	85°	84,73	87,38	30
75°	85°	76,10	76,98	20

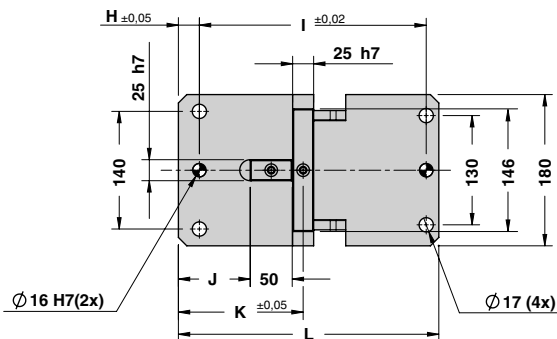

Cam Units CHV





AERIAL CAM UNIT - OBEN HÄNGENDER SCHIEBER - UNITÀ A CAMME SOSPESA

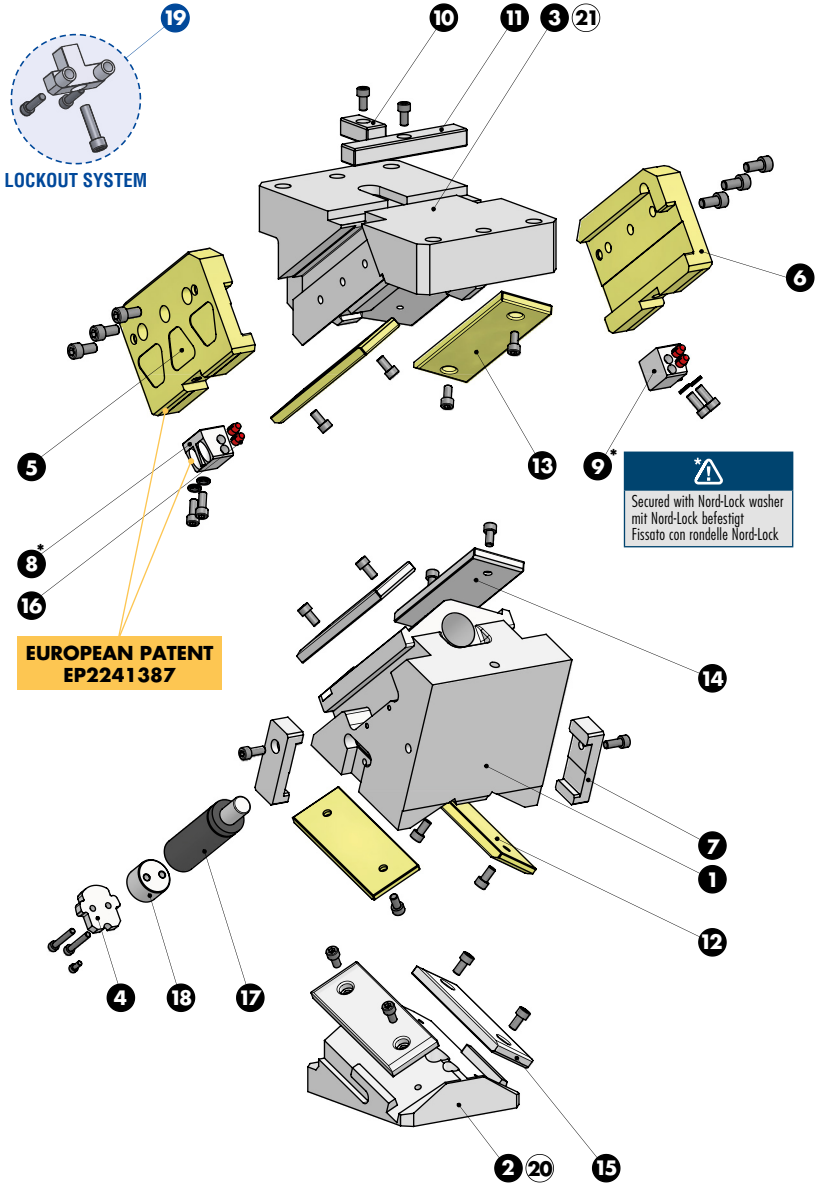



**AERIAL CAM UNIT - OBEN HÄNGENDER SCHIEBER - UNITÀ A CAMME SOSPESA**

SLIDER STRUCTURE, POSITIVE RETURN STRUCTURE AND CLEARANCES

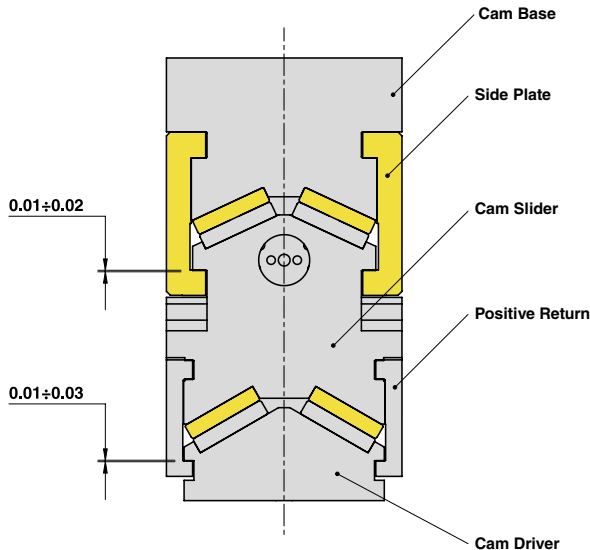

Cam Units CHV

PART LIST

Particular number	Description	Material	Quantity
1	Cam Slider	GGG-60	1
2	Cam Driver	GGG-60	1
3	Cam Base	GGG-60	1
4	Lock Plate	42CrMo4	1
5	Side Plate L	CuZn25Al5 + Graphite - HB > 190	1
6	Side Plate R	CuZn25Al5 + Graphite - HB > 190	1
7	Positive Return	42CrMo4 Nitrided	2
8	Slide Reaction L	CK45	1
9	Slide Reaction R	CK45	1
10	Key	CK45	1
11	Key	CK45	1
12	Wear Plate VDI 3357	CuZn25Al5 + Graphite - HB > 190	2
13	Wear Plate VDI 3357	CuZn25Al5 + Graphite - HB > 190	2
14	Wear Plate VDI 3357	16MnCr5 - HRC 58÷60	2
15	Wear Plate VDI 3357	16MnCr5 - HRC 58÷60	2
16	Elastomer Cap	Elastomer 92SH	4
17	Gas Spring	-	1
18	Spring Spacer	CK45	1
19	LOCKOUT SYSTEM	(more info on OMCR website)	1
20	Cam Driver Fixing Screws M16x55 DIN 912	-	4
21	Cam Base Fixing Screws M16x65 DIN 912	-	4



## AERIAL CAM UNIT - OBEN HÄNGENDER SCHIEBER - UNITÀ A CAMME SOSPESA

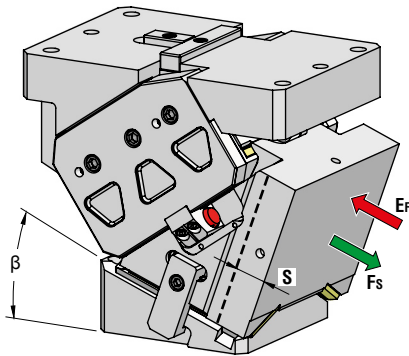

OMCR CODE	Work Angle	Stroke (mm)	Max Work Force with shoulder (kN)	Extraction Force (kN)
	$\beta$	S	Fs	Ef Gas Spring
CHV220.00	0°	32,14	635	18,8
CHV220.05	5°	35,49	648	19,3
CHV220.10	10°	35,90	661	20,1
CHV220.15	15°	39,65	674	20,9
CHV220.20	20°	43,59	687	21,8
CHV220.25	25°	45,19	700	22,7
CHV220.30	30°	50	714	24,1
CHV220.35	35°	52,86	727	24,8
CHV220.40	40°	59,16	727	26,8
CHV220.45	45°	64,09	728	27,5
CHV220.50	50°	73,10	729	30,4
CHV220.55	55°	81,92	729	31,1
CHV220.60	60°	96,59	730	35,3
CHV220.65	65°	91,42	730	37,1
CHV220.70	70°	100,78	731	43,9
CHV220.75	75°	95,13	732	44,5

15



Art.	Work Angle = 5°
CHV220	05

OMCR CODE	Work Angle	Overall Dimensions (mm)										
		$\beta$	A	B	C	D	E	F	G	H	I	J
CHV220.00	0°	308	60	80	295	215	155	25	280	64	127	320
CHV220.05	5°	317,63	64,37	80	290	210	155	25	280	71,5	134,5	320
CHV220.10	10°	323,81	89,28	80	280	200	155	25	280	79	142	320
CHV220.15	15°	331,70	94,96	80	270	190	155	25	280	88	151	320
CHV220.20	20°	337,80	106,02	80	265	185	155	25	280	95,5	158,5	320
CHV220.25	25°	345,05	112,89	60	255	195	150	15	330	104,5	167,5	360
CHV220.30	30°	357,11	116,73	60	250	190	150	15	330	112	175	360
CHV220.35	35°	362,94	132,76	60	245	185	150	15	330	119,5	182,5	360
CHV220.40	40°	373,16	142,98	60	240	180	150	15	330	127	190	360
CHV220.45	45°	348,64	154,39	45	205	160	130	15	335	98	161	365
CHV220.50	50°	355,42	170,24	45	205	160	130	15	335	104	167	365
CHV220.55	55°	361,67	186,67	45	206	161	130	15	335	89,5	152,5	365
CHV220.60	60°	371,66	201,11	45	204	159	130	15	335	96,5	159,5	365
CHV220.65	65°	367,84	213,13	45	206	161	130	15	335	96,5	159,5	365
CHV220.70	70°	372,05	220,55	45	208	163	130	15	335	96,5	159,5	365
CHV220.75	75°	352,07	246,93	35	180	145	115	15	335	96,5	159,5	365



AERIAL CAM UNIT - OBEN HÄNGENDER SCHIEBER - UNITÀ A CAMME SOSPESA

X VIEW

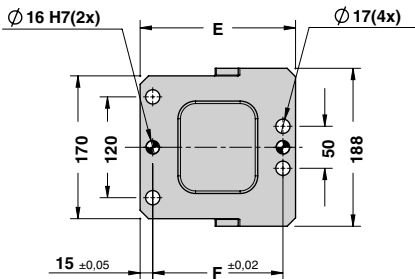
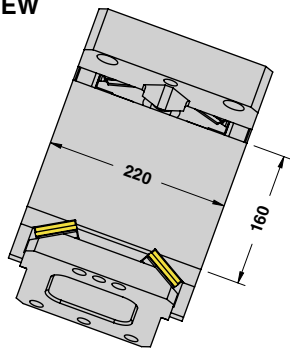

CAM DIAGRAM

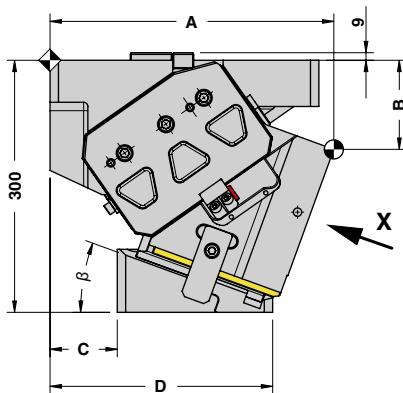
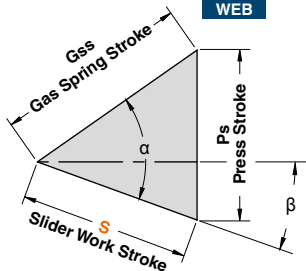

Work Angle	Inner Angle	Slider Work Stroke (mm)	Press Stroke (mm)	Gas Spring Stroke (mm)
$\beta$	$\alpha$	S	Ps	Gss

0°	50°	32,14	38,30	50
5°	50°	35,49	38,45	50
10°	55°	35,90	41,59	50
15°	55°	39,65	42,40	50
20°	55°	43,59	43,59	50
25°	60°	45,19	47,78	50
30°	60°	50,00	50,00	50
35°	65°	52,86	55,32	50
40°	65°	59,16	59,16	50
45°	70°	64,09	66,45	50
50°	70°	73,10	73,10	50
55°	75°	81,92	84,20	50
60°	75°	96,59	96,59	50
65°	80°	91,42	93,21	40
70°	80°	100,78	100,78	35
75°	85°	95,13	96,23	25

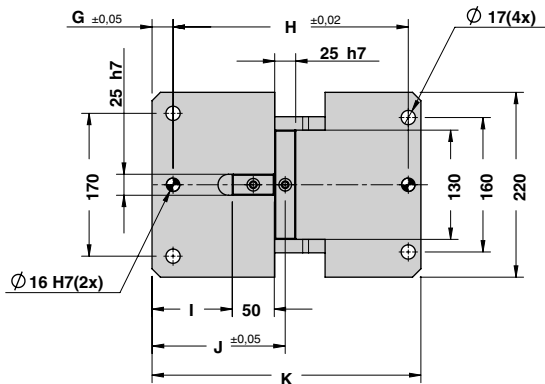

Cam Units CHV



AERIAL CAM UNIT - OBEN HÄNGENDER SCHIEBER - UNITÀ A CAMME SOSPESA

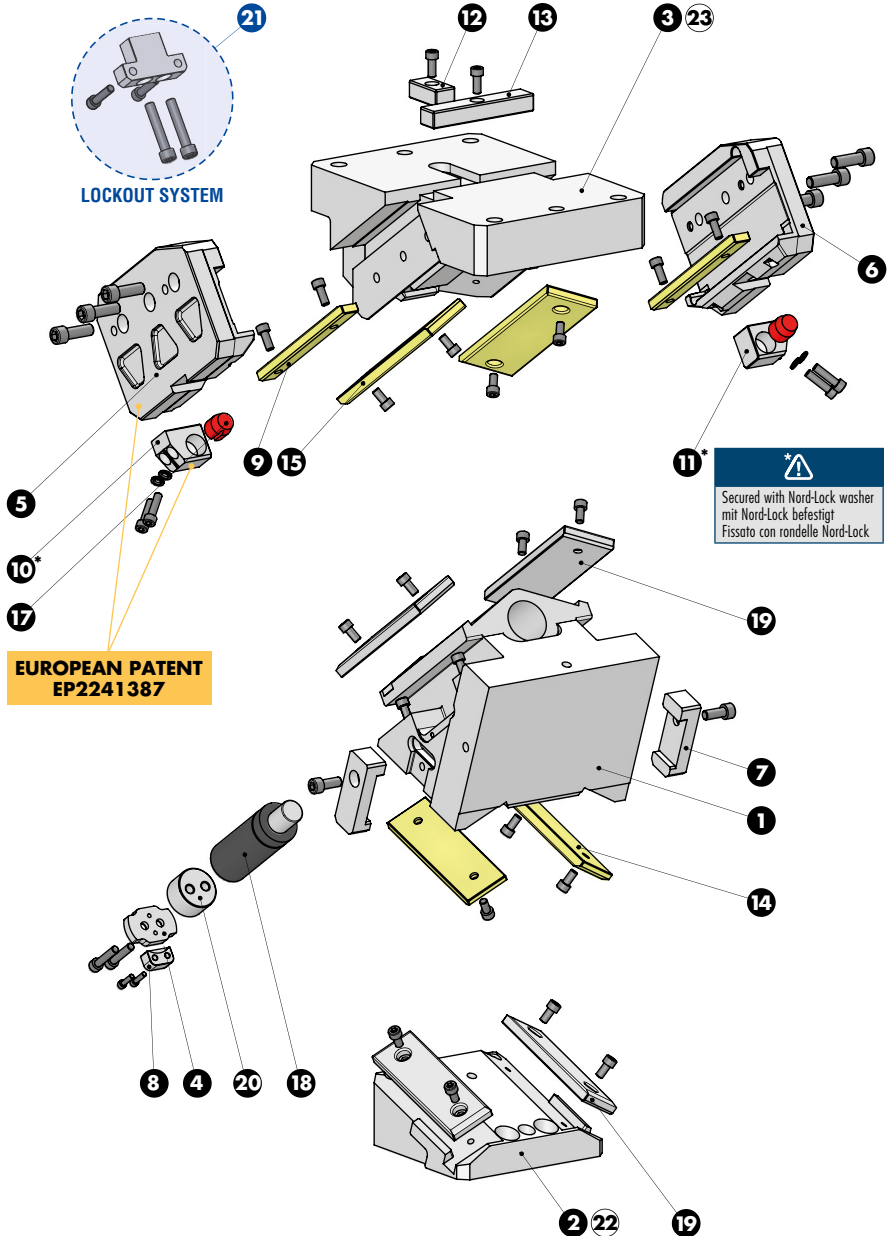



**AERIAL CAM UNIT - OBEN HÄNGENDER SCHIEBER - UNITÀ A CAMME SOSPESA**

SLIDER STRUCTURE, POSITIVE RETURN STRUCTURE AND CLEARANCES

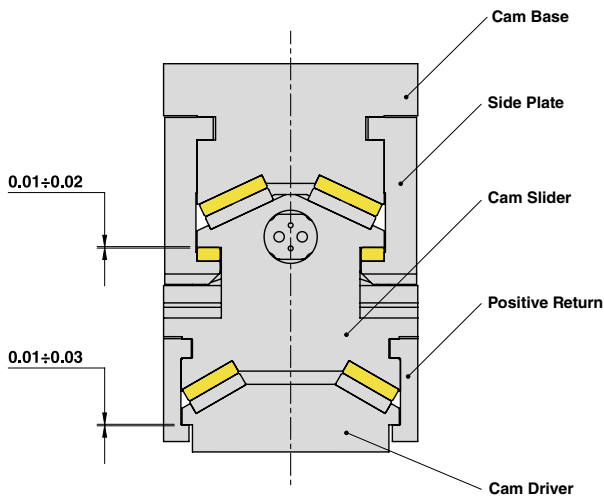

Cam Units CHV

PART LIST

Particular number	Description	Material	Quantity
1	Cam Slider	GGG-60	1
2	Cam Driver	GGG-60	1
3	Cam Base	GGG-60	1
4	Lock Plate	42CrMo4	1
5	Side Plate L	42CrMo4	1
6	Side Plate R	42CrMo4	1
7	Positive Return	42CrMo4 Nitrided	2
8	Safety Plate	CK45	1
9	Wear Plate	CuZn25Al5 + Graphite - HB > 190	2
10	Slide Reaction L	CK45	1
11	Slide Reaction R	CK45	1
12	Key	CK45	1
13	Key	CK45	1
14	Wear Plate VDI 3357	CuZn25Al5 + Graphite - HB > 190	2
15	Wear Plate VDI 3357	CuZn25Al5 + Graphite - HB > 190	2
16	Wear Plate VDI 3357	16MnCr5 - HRC 58÷60	2
17	Elastomer Cap	Elastomer 92SH	2
18	Gas Spring	-	1
19	Wear Plate VDI 3357	16MnCr5 - HRC 58÷60	2
20	Spring Spacer	CK45	1
21	<b>LOCKOUT SYSTEM</b>	(more info on OMCR website)	1
22	Cam Driver Fixing Screws M16x55 DIN 912	-	4
23	Cam Base Fixing Screws M16x65 DIN 912	-	4



## AERIAL CAM UNIT - OBEN HÄNGENDER SCHIEBER - UNITÀ A CAMME SOSPESA

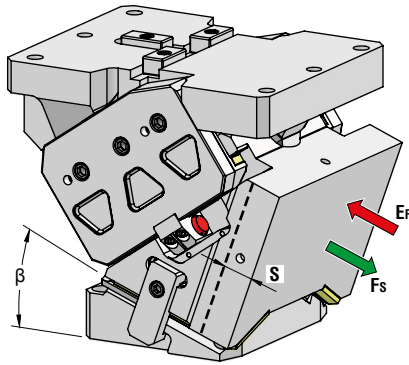

OMCR CODE	Work Angle	Stroke (mm)	Max Work Force with shoulder (kN)	Extraction Force (kN)
	β	S	F <sub>s</sub>	E <sub>F</sub> Gas Spring
CHV260.00	0°	32,14	536	30,5
CHV260.05	5°	35,49	564	30,8
CHV260.10	10°	35,90	593	31,3
CHV260.15	15°	39,65	621	31,7
CHV260.20	20°	43,59	650	32,4
CHV260.25	25°	45,19	673	32,7
CHV260.30	30°	50	690	33,7
CHV260.35	35°	52,86	708	33,9
CHV260.40	40°	59,16	737	35,2
CHV260.45	45°	64,09	744	35,2
CHV260.50	50°	73,10	747	37,0
CHV260.55	55°	81,92	751	36,9
CHV260.60	60°	96,59	755	39,5
CHV260.65	65°	91,42	759	40,7
CHV260.70	70°	100,78	763	45,7
CHV260.75	75°	95,13	767	45,3

15



Art.	Work Angle = 5°
CHV260	05

OMCR CODE	Work Angle	Overall Dimensions (mm)															
	β	A	B	C	D	E	F	G	H	I	J	K	L	M	N	O	P
CHV260.00	0°	308	60	80	295	215	155	204	70	15	155	25	280	63,5	50	127	320
CHV260.05	5°	317,63	64,37	80	290	210	155	204	90	15	155	25	280	70,5	50	134	320
CHV260.10	10°	323,81	89,28	80	280	200	155	204	70	15	155	25	280	78,5	50	142	320
CHV260.15	15°	331,70	94,96	80	270	190	155	204	70	15	155	25	280	76	50	151	320
CHV260.20	20°	337,80	106,02	80	265	185	155	204	70	15	155	25	280	76	50	151	320
CHV260.25	25°	345,05	112,89	60	255	195	150	204	70	15	150	15	330	100	50	167,5	360
CHV260.30	30°	357,11	116,73	60	250	190	150	204	70	15	150	15	330	105	50	175	360
CHV260.35	35°	362,94	132,76	60	245	185	150	204	70	15	150	15	330	115	50	182,5	360
CHV260.40	40°	373,16	142,98	60	240	180	150	204	70	15	150	15	330	120	50	190	360
CHV260.45	45°	348,64	154,39	45	205	160	130	204	70	15	130	15	335	90	50	161	365
CHV260.50	50°	355,42	170,24	45	205	160	130	204	70	15	130	15	335	100	50	167	365
CHV260.55	55°	361,67	186,67	45	215	170	130	204	70	15	130	15	335	85	50	152,5	365
CHV260.60	60°	371,66	201,11	45	205	160	130	204	70	15	130	15	335	90	50	159,5	365
CHV260.65	65°	367,84	213,13	45	211	166	120	204	70	20	120	15	335	90	50	159,5	365
CHV260.70	70°	372,05	220,55	45	210	165	130	226	90	15	130	15	335	90	50	159,5	365
CHV260.75	75°	352,07	246,93	35	185	150	115	226	90	15	115	15	335	90	50	159,5	365





AERIAL CAM UNIT - OBEN HÄNGENDER SCHIEBER - UNITÀ A CAMME SOSPESA

X VIEW

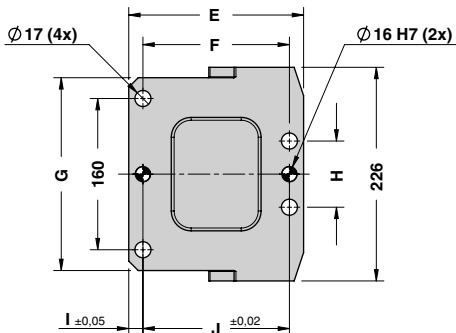
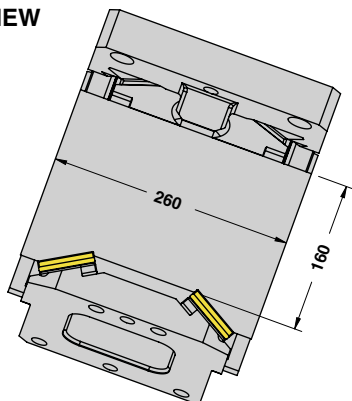

CAM DIAGRAM

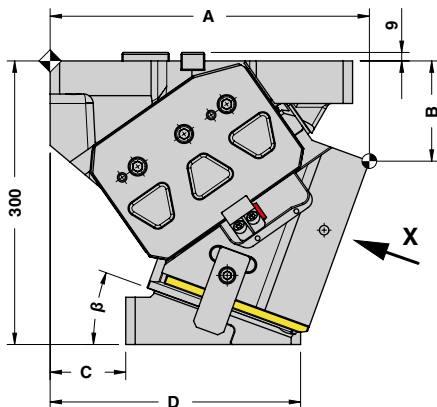
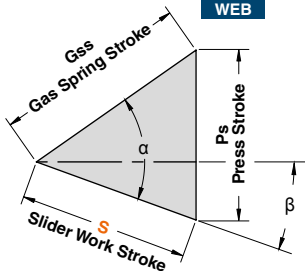

Work Angle	Inner Angle	Slider Work Stroke (mm)	Press Stroke (mm)	Gas Spring Stroke (mm)
$\beta$	$\alpha$	S	Ps	Gss
0°	50°	32,14	38,30	50
5°	50°	35,49	38,45	50
10°	55°	35,90	41,59	50
15°	55°	39,65	42,40	50
20°	55°	43,59	43,59	50
25°	60°	45,19	47,78	50
30°	60°	50,00	50,00	50
35°	65°	52,86	55,32	50
40°	65°	59,16	59,16	50
45°	70°	64,09	66,45	50
50°	70°	73,10	73,10	50
55°	75°	81,92	84,20	50
60°	75°	96,59	96,59	50
65°	80°	91,42	93,21	40
70°	80°	100,78	100,78	35
75°	85°	95,13	96,23	25

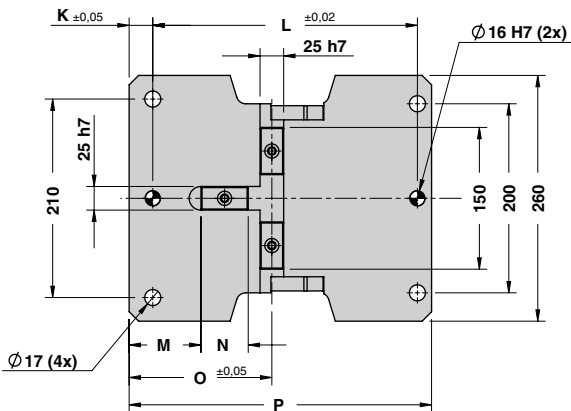

Cam Units CHV





AERIAL CAM UNIT - OBEN HÄNGENDER SCHIEBER - UNITÀ A CAMME SOSPESA

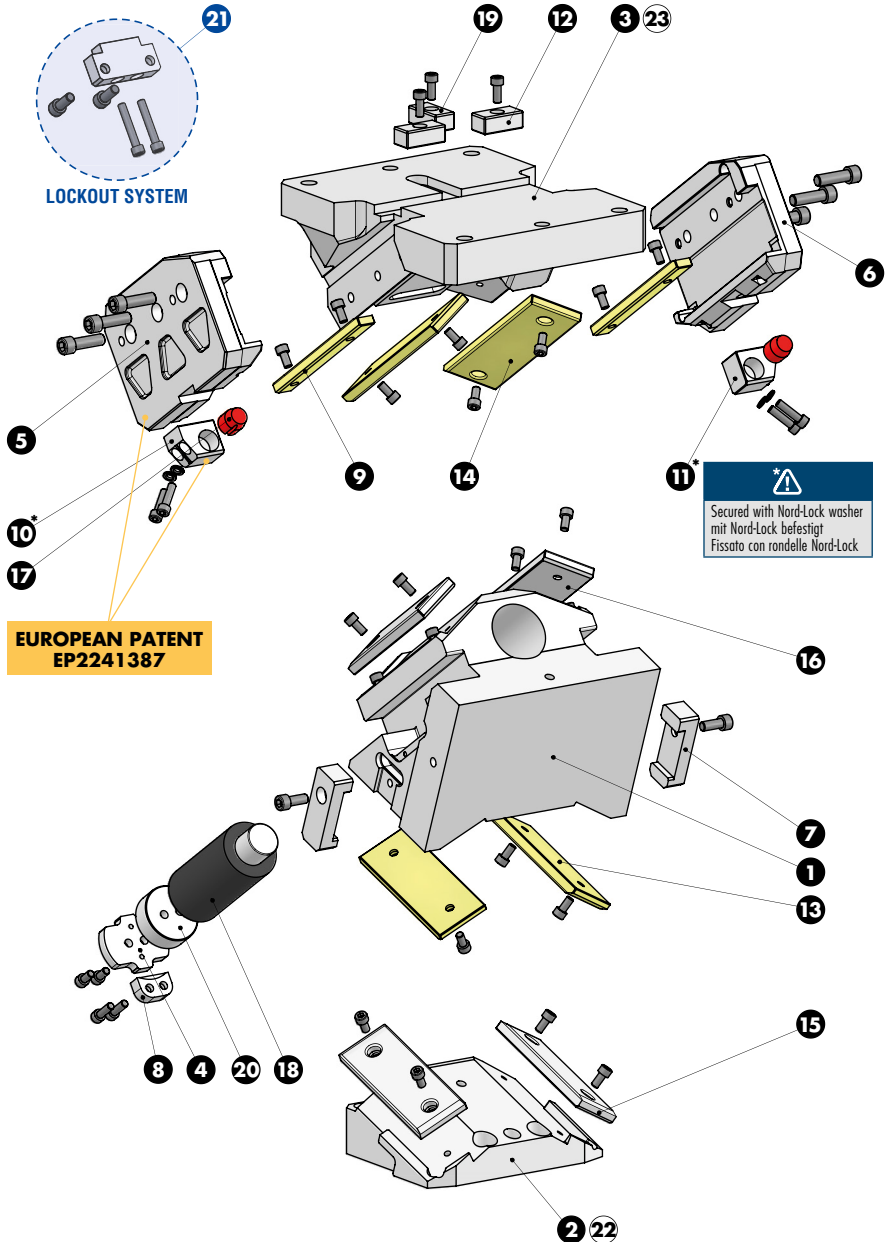

**EUROPEAN PATENT  
EP2241387**

**11\***  

 Secured with Nord-Lock washer  
 mit Nord-Lock befestigt  
 Fissato con rondelle Nord-Lock



**AERIAL CAM UNIT - OBEN HÄNGENDER SCHIEBER - UNITÀ A CAMME SOSPESA**

**SLIDER STRUCTURE, POSITIVE RETURN STRUCTURE AND CLEARANCES**

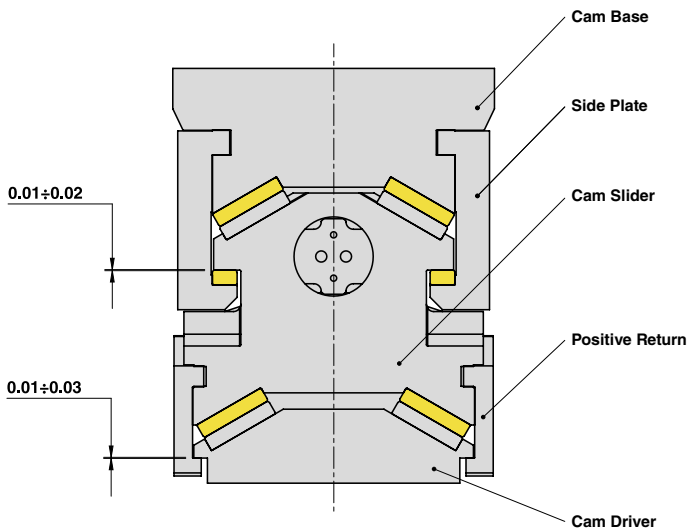

**PART LIST**

Particular number	Description	Material	Quantity
1	Cam Slider	GGG-60	1
2	Cam Driver	GGG-60	1
3	Cam Base	GGG-60	1
4	Lock Plate	42CrMo4	1
5	Side Plate L	42CrMo4	1
6	Side Plate R	42CrMo4	1
7	Positive Return	42CrMo4 Nitrided	2
8	Safety Plate	CK45	1
9	Wear Plate	CuZn25Al5 + Graphite - HB > 190	2
10	Slide Reaction L	CK45	1
11	Slide Reaction R	CK45	1
12	Key	CK45	2
13	Wear Plate VDI 3357	CuZn25Al5 + Graphite - HB > 190	2
14	Wear Plate VDI 3357	CuZn25Al5 + Graphite - HB > 190	2
15	Wear Plate VDI 3357	16MnCr5 - HRC 58÷60	2
16	Wear Plate VDI 3357	16MnCr5 - HRC 58÷60	2
17	Elastomer Cap	Elastomer 92SH	2
18	Gas Spring	-	1
19	Key	CK45	1
20	Spring Spacer (not included for CHV260.15-20-55-65)	CK45	1
21	<b>LOCKOUT SYSTEM</b>	(more info on OMCR website)	1
22	Cam Driver Fixing Screws M16x55 DIN 912	-	4
23	Cam Base Fixing Screws M16x65 DIN 912	-	4

Cam Units CHV





## AERIAL CAM UNIT - OBEN HÄNGENDER SCHIEBER - UNITÀ A CAMME SOSPESA

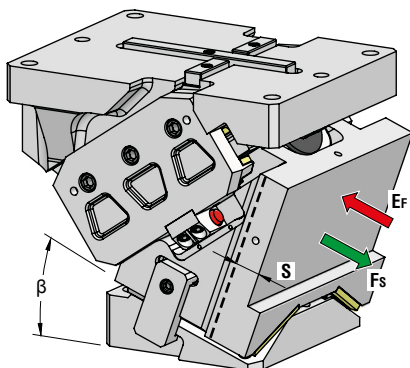

OMCR CODE	Work Angle	Stroke (mm)	Max Work Force with shoulder (kN)	Extraction Force (kN)
	β	S	Fs	Ef Gas Spring
CHV330.00	0°	37,28	1006	63,9
CHV330.05	5°	41,17	1005	64,6
CHV330.10	10°	41,64	1005	66,6
CHV330.15	15°	46	1005	67,8
CHV330.20	20°	50,56	1007	69,5
CHV330.25	25°	52,42	1009	71,2
CHV330.30	30°	58	1010	73,7
CHV330.35	35°	61,32	1012	75,1
CHV330.40	40°	68,62	1013	78,5
CHV330.45	45°	74,34	1014	79,6
CHV330.50	50°	84,79	1015	84,4
CHV330.55	55°	95,02	1016	85,1
CHV330.60	60°	112,05	1017	91,8
CHV330.65	65°	102,85	1018	94,8
CHV330.70	70°	127,09	1019	94,9
CHV330.75	75°	114,15	1020	95,9

15



Art.	Work Angle = 5°
CHV330	05

OMCR CODE	Work Angle	Overall Dimensions (mm)														
	β	A	B	C	D	E	F	G	H	I	J	K	L	M	N	O
CHV330.00	0°	403	75	130	410	280	185	254	170	60	285	205	365	72	209,5	415
CHV330.05	5°	410,89	94,30	130	398	268	185	254	170	50	285	205	365	82,5	220	415
CHV330.10	10°	418,81	99,28	130	384	254	185	254	170	50	285	205	365	93	230,5	415
CHV330.15	15°	426,70	104,96	130	385	255	185	254	170	50	285	205	365	103,5	241	415
CHV330.20	20°	434,51	111,32	130	375	245	185	254	170	50	285	205	365	94	251,5	415
CHV330.25	25°	417,16	118,36	80	339	259	145	254	170	50	285	175	365	104,5	237	415
CHV330.30	30°	424,61	131,06	80	330	250	145	254	170	50	285	175	365	95	247,5	415
CHV330.35	35°	427,78	150,13	80	317	237	145	254	170	50	285	175	365	104	256,5	415
CHV330.40	40°	438,66	158,34	80	312	232	145	254	170	50	285	175	365	98	265,5	415
CHV330.45	45°	395,15	172,88	30	255	225	145	254	170	50	285	175	401	62	224,5	450
CHV330.50	50°	412,72	188,31	30	252	222	145	254	170	50	285	175	401	56	233,5	450
CHV330.55	55°	423,22	212,08	30	256	226	145	254	170	50	285	175	401	63,4	240,9	450
CHV330.60	60°	433,59	232,11	30	258	228	145	254	170	50	285	175	401	71	248,5	450
CHV330.65	65°	434,62	242,64	0	242	242	140	330	293	293	330	175	401	71	248,5	450
CHV330.70	70°	429,87	254,52	0	232	232	125	330	293	293	330	175	401	71	248,5	450
CHV330.75	75°	418,49	262,53	0	221	221	105	330	293	293	330	160	401	56	233,5	450





AERIAL CAM UNIT - OBEN HÄNGENDER SCHIEBER - UNITÀ A CAMME SOSPESA

X VIEW

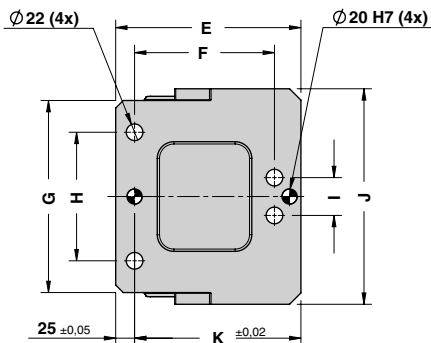
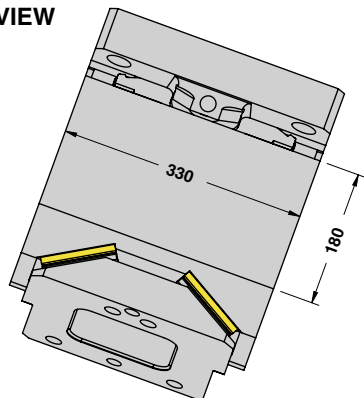

CAM DIAGRAM

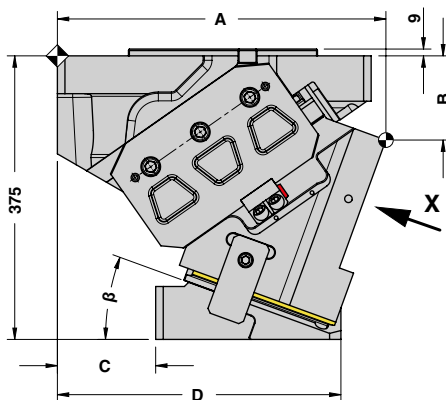
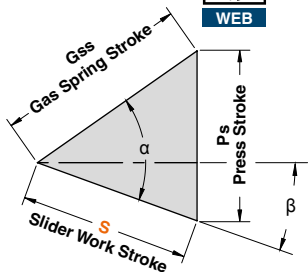

Work Angle	Inner Angle	Slider Work Stroke (mm)	Press Stroke (mm)	Gas Spring Stroke (mm)
$\beta$	$\alpha$	S	Ps	Gss
0°	50°	37,28	44,43	58
5°	50°	41,17	44,60	58
10°	55°	41,64	48,24	58
15°	55°	46,00	49,19	58
20°	55°	50,56	50,56	58
25°	60°	52,42	55,42	58
30°	60°	58,00	58,00	58
35°	65°	61,32	64,17	58
40°	65°	68,62	68,62	58
45°	70°	74,34	77,08	58
50°	70°	84,79	84,79	58
55°	75°	95,02	97,67	58
60°	75°	112,05	112,05	58
65°	80°	102,85	104,86	45
70°	85°	127,09	131,07	45
75°	85°	114,15	115,47	30

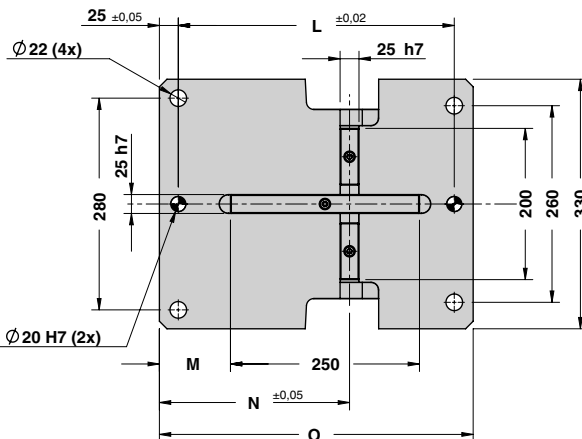

Cam Units CHV



AERIAL CAM UNIT - OBEN HÄNGENDER SCHIEBER - UNITÀ A CAMME SOSPESA

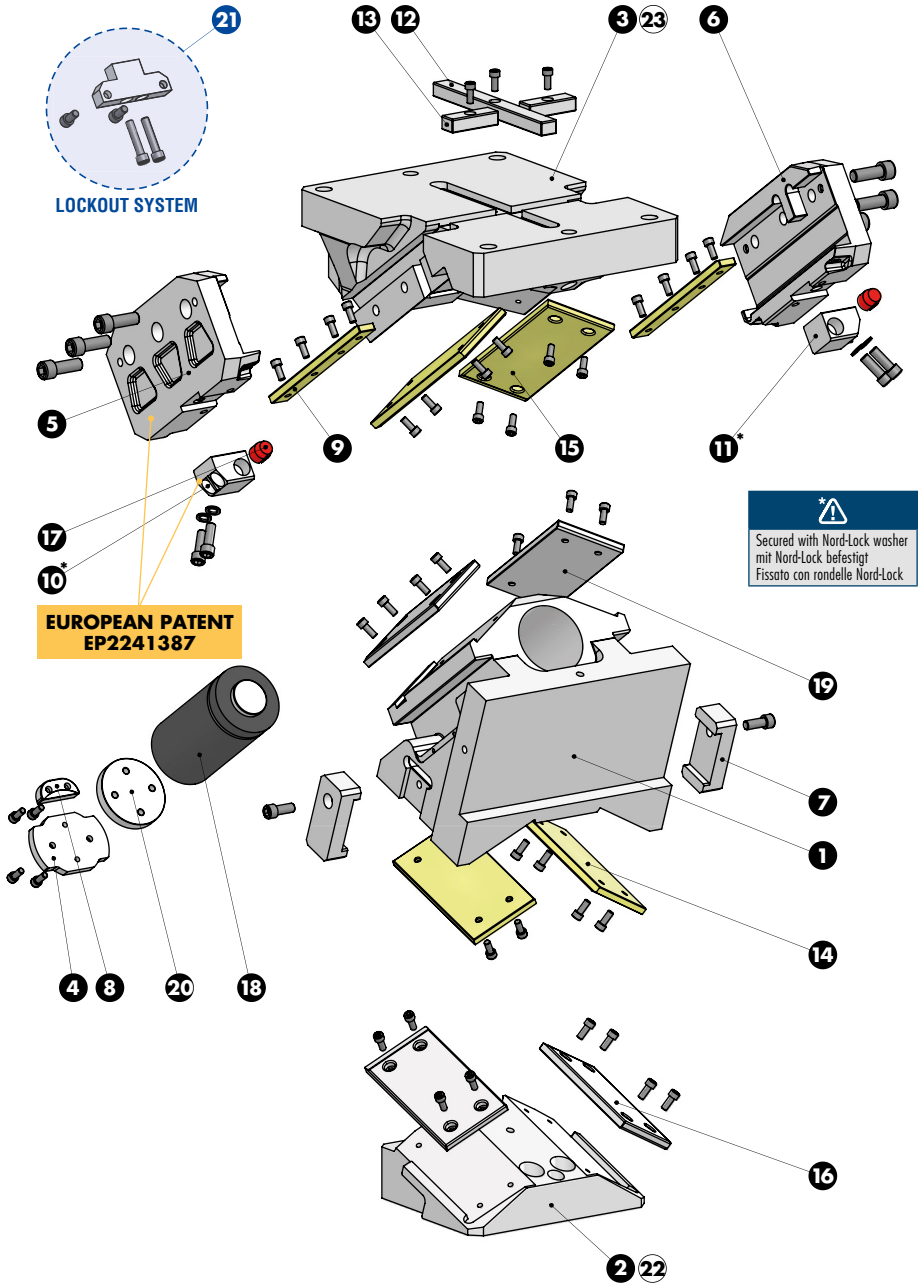



**AERIAL CAM UNIT - OBEN HÄNGENDER SCHIEBER - UNITÀ A CAMME SOSPESA**

**SLIDER STRUCTURE, POSITIVE RETURN STRUCTURE AND CLEARANCES**

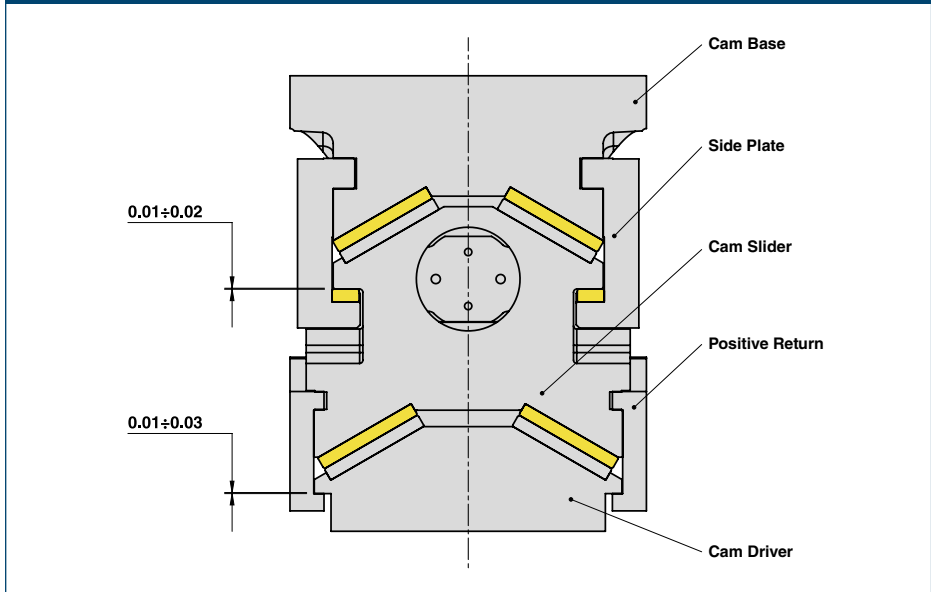

Cam Units CHV

**PART LIST**

Particular number	Description	Material	Quantity
1	Cam Slider	GGG-60	1
2	Cam Driver	GGG-60	1
3	Cam Base	GGG-60	1
4	Lock Plate	42CrMo4	1
5	Side Plate L	42CrMo4	1
6	Side Plate R	42CrMo4	1
7	Positive Return	42CrMo4 Nitrided	2
8	Safety Plate	CK45	1
9	Wear Plate	CuZn25Al5 + Graphite - HB > 190	2
10	Slide Reaction L	CK45	1
11	Slide Reaction R	CK45	1
12	Key	CK45	1
13	Key	CK45	2
14	Wear Plate VDI 3357	CuZn25Al5 + Graphite - HB > 190	2
15	Wear Plate VDI 3357	CuZn25Al5 + Graphite - HB > 190	2
16	Wear Plate VDI 3357	16MnCr5 - HRC 58÷60	2
17	Elastomer Cap	Elastomer 92SH	2
18	Gas Spring	-	1
19	Wear Plate VDI 3357	16MnCr5 - HRC 58÷60	2
20	Spring Spacer (included only for CHV330.20 and CHV330.35)	CK45	1
21	<b>LOCKOUT SYSTEM</b>	(more info on OMCR website)	1
22	Cam Driver Fixing Screws M20x70 DIN 912	-	4
23	Cam Base Fixing Screws M20x70 DIN 912	-	4



## AERIAL CAM UNIT - OBEN HÄNGENDER SCHIEBER - UNITÀ A CAMME SOSPESA

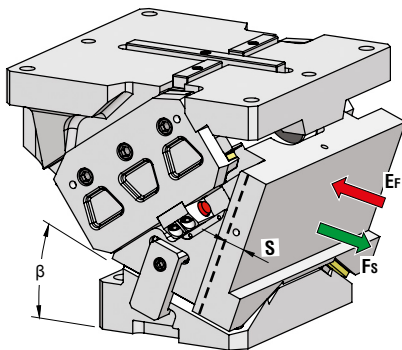

OMCR CODE	Work Angle	Stroke (mm)	Max Work Force with shoulder (kN)	Extraction Force (kN)
	$\beta$	S	$F_s$	$E_f$ Gas Spring
CHV400.00	0°	37,28	1055	63,9
CHV400.05	5°	41,17	1055	64,6
CHV400.10	10°	41,64	1054	66,6
CHV400.15	15°	46	1054	67,8
CHV400.20	20°	50,56	1054	69,5
CHV400.25	25°	52,42	1054	71,2
CHV400.30	30°	58	1054	73,7
CHV400.35	35°	61,32	1054	75,1
CHV400.40	40°	68,62	1054	78,5
CHV400.45	45°	74,34	1054	79,6
CHV400.50	50°	84,79	1053	84,4
CHV400.55	55°	95,02	1053	85,1
CHV400.60	60°	112,05	1053	91,8
CHV400.65	65°	102,85	1053	94,8
CHV400.70	70°	127,09	1053	94,9
CHV400.75	75°	114,15	1052	95,9

20



Art.	Work Angle = 5°
CHV400	05

OMCR CODE	Work Angle	Overall Dimensions (mm)														
		$\beta$	A	B	C	D	E	F	G	H	I	J	K	L	M	N
CHV400.00	0°	403	75	130	410	280	185	318	240	90	338	205	365	72	209,5	415
CHV400.05	5°	410,89	94,30	130	410	280	185	318	240	90	338	205	365	82,5	220	415
CHV400.10	10°	418,81	99,28	130	385	255	185	318	240	90	338	205	365	93	230,5	415
CHV400.15	15°	426,70	104,96	130	385	255	185	318	240	90	338	205	365	103,5	241	415
CHV400.20	20°	434,51	111,32	130	375	245	185	318	240	90	338	205	365	94	251,5	415
CHV400.25	25°	417,16	118,36	80	340	260	145	318	240	90	338	175	365	104,5	237	415
CHV400.30	30°	424,61	131,06	80	330	250	145	318	240	90	338	175	365	95	247,5	415
CHV400.35	35°	427,78	150,13	80	317	237	145	318	240	90	338	175	365	104	256,5	415
CHV400.40	40°	438,66	158,34	80	310	230	145	318	240	90	338	175	365	98	265,5	415
CHV400.45	45°	395,15	172,88	30	255	225	145	318	240	90	338	175	401	62	224,5	450
CHV400.50	50°	412,72	188,31	30	245	215	145	318	240	90	338	175	401	56	233,5	450
CHV400.55	55°	423,22	212,08	30	256	226	145	318	240	90	338	175	401	63,4	240,9	450
CHV400.60	60°	433,59	232,11	30	260	230	145	318	240	90	338	175	401	71	248,5	450
CHV400.65	65°	434,62	242,64	0	242	242	140	400	363	363	400	175	401	71	248,5	450
CHV400.70	70°	429,87	254,52	0	226	226	125	400	363	363	400	175	401	71	248,5	450
CHV400.75	75°	418,49	262,53	0	214	214	105	400	363	363	400	160	401	56	233,5	450





## AERIAL CAM UNIT - OBEN HÄNGENDER SCHIEBER - UNITÀ A CAMME SOSPESA

### X VIEW

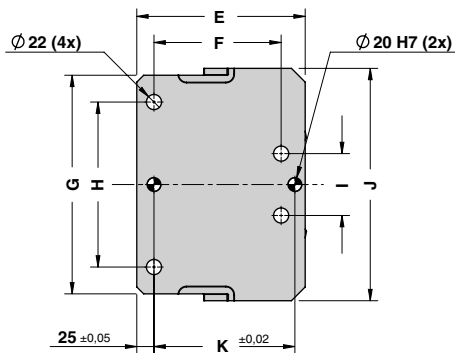
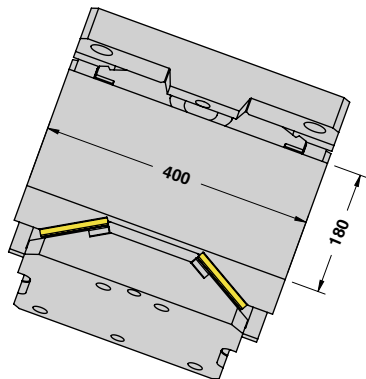

### CAM DIAGRAM

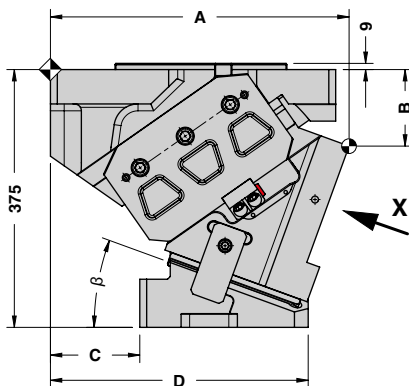
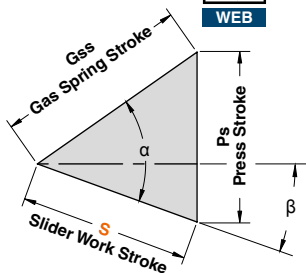

Work Angle	Inner Angle	Slider Work Stroke (mm)	Press Stroke (mm)	Gas Spring Stroke (mm)
$\beta$	$\alpha$	S	Ps	Gss

0°	50°	37,28	44,43	58
5°	50°	41,17	44,60	58
10°	55°	41,64	48,24	58
15°	55°	46,00	49,19	58
20°	55°	50,56	50,56	58
25°	60°	52,42	55,42	58
30°	60°	58,00	58,00	58
35°	65°	61,32	64,17	58
40°	65°	68,62	68,62	58
45°	70°	74,34	77,08	58
50°	70°	84,79	84,79	58
55°	75°	95,02	97,67	58
60°	75°	112,05	112,05	58
65°	80°	102,85	104,86	45
70°	85°	127,09	131,07	45
75°	85°	114,15	115,47	30

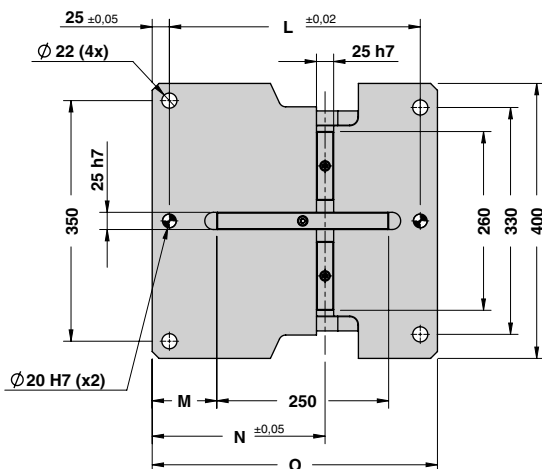





## AERIAL CAM UNIT - OBEN HÄNGENDER SCHIEBER - UNITÀ A CAMME SOSPESA

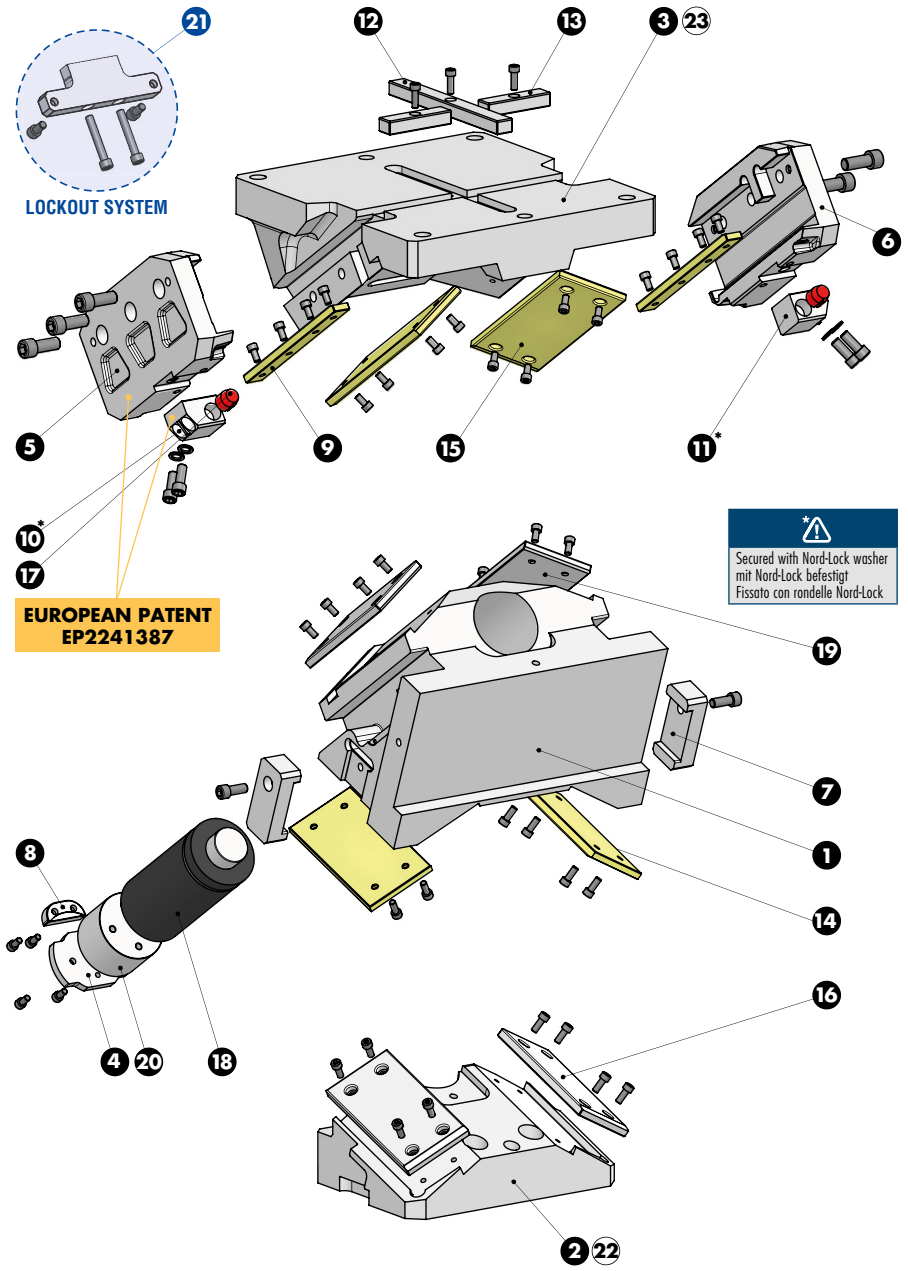

LOCKOUT SYSTEM

EUROPEAN PATENT  
EP2241387

 Secured with Nord-Lock washer  
mit Nord-Lock befestigt  
Fissato con rondelle Nord-Lock



**AERIAL CAM UNIT - OBEN HÄNGENDER SCHIEBER - UNITÀ A CAMME SOSPESA**

SLIDER STRUCTURE, POSITIVE RETURN STRUCTURE AND CLEARANCES

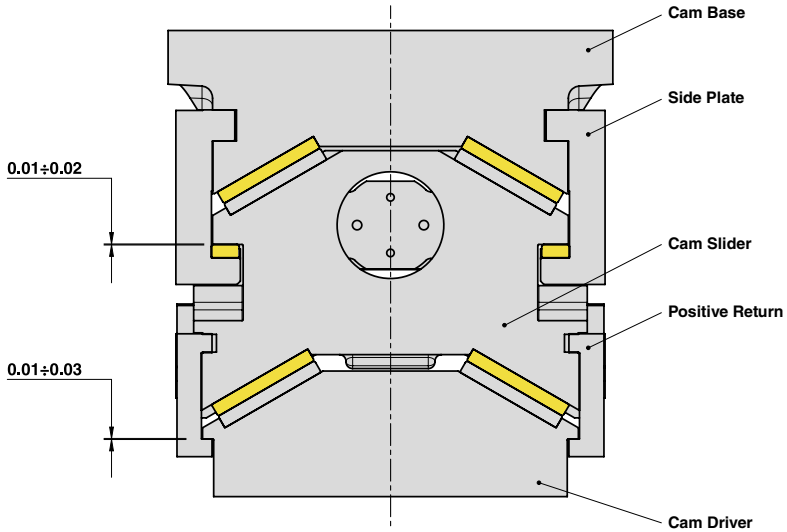

Cam Units CHV

PART LIST

Particular number	Description	Material	Quantity
1	Cam Slider	GGG-60	1
2	Cam Driver	GGG-60	1
3	Cam Base	GGG-60	1
4	Lock Plate	42CrMo4	1
5	Side Plate L	42CrMo4	1
6	Side Plate R	42CrMo4	1
7	Positive Return	42CrMo4 Nitrided	2
8	Safety Plate	CK45	1
9	Wear Plate	CuZn25Al5 + Graphite - HB > 190	2
10	Slide Reaction L	CK45	1
11	Slide Reaction R	CK45	1
12	Key	CK45	1
13	Key	CK45	2
14	Wear Plate VDI 3357	CuZn25Al5 + Graphite - HB > 190	2
15	Wear Plate VDI 3357	CuZn25Al5 + Graphite - HB > 190	2
16	Wear Plate VDI 3357	16MnCr5 - HRC 58-60	2
17	Elastomer Cap	Elastomer 92SH	2
18	Gas Spring	-	1
19	Wear Plate VDI 3357	16MnCr5 - HRC 58-60	2
20	Spring Spacer (included only for CHV400.65)	CK45	1
21	LOCKOUT SYSTEM	(more info on OMCR website)	1
22	Cam Driver Fixing Screws M20x70 DIN 912	-	4
23	Cam Base Fixing Screws M20x70 DIN 912	-	4



## AERIAL CAM UNIT - OBEN HÄNGENDER SCHIEBER - UNITÀ A CAMME SOSPESA

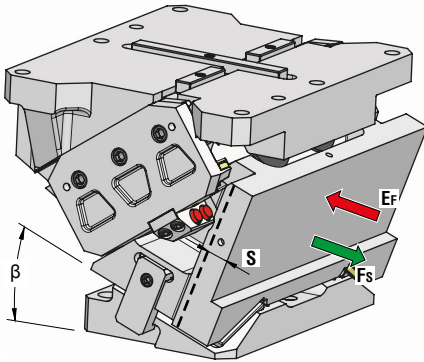

OMCR CODE	Work Angle	Stroke (mm)	Max Work Force with shoulder (kN)	Extraction Force (kN)
	$\beta$	S	F <sub>s</sub>	E <sub>f</sub> Gas Spring
CHV500.00	0°	37,28	1155	87,0
CHV500.05	5°	41,17	1155	87,0
CHV500.10	10°	41,64	1155	85,7
CHV500.15	15°	46,00	1155	85,7
CHV500.20	20°	50,56	1155	85,7
CHV500.25	25°	52,42	1155	83,8
CHV500.30	30°	58,00	1155	83,8
CHV500.35	35°	61,32	1155	81,2
CHV500.40	40°	68,62	1155	81,2
CHV500.45	45°	74,34	1155	78,0
CHV500.50	50°	84,79	1155	78,0
CHV500.55	55°	95,02	1155	74,1
CHV500.60	60°	112,05	1155	74,1
CHV500.65	65°	102,85	1155	69,3
CHV500.70	70°	127,09	1155	64,5
CHV500.75	75°	114,15	1155	66,8

30



Art.	Work Angle = 5°
CHV500	05

OMCR CODE	Work Angle	Overall Dimensions (mm)															
		$\beta$	A	B	C	D	E	F	G	H	I	J	K	L	M	N	O
CHV500.00	0°	403,00	75,00	130	410	280	185	408	340	190	438	205	365	83	209,5	415	110
CHV500.05	5°	410,89	94,30	130	410	280	185	408	340	190	438	205	365	83	220	415	110
CHV500.10	10°	418,81	99,28	130	397	267	185	408	340	190	438	205	365	83	230,5	415	110
CHV500.15	15°	426,70	104,96	130	397	267	185	408	340	190	438	205	365	83	241	415	110
CHV500.20	20°	434,51	111,32	130	388	258	185	408	340	190	438	205	365	83	251,5	415	110
CHV500.25	25°	417,16	118,36	80	350	270	145	408	340	190	438	175	365	83	237	415	110
CHV500.30	30°	424,61	131,06	80	340	260	145	408	340	180	438	175	365	83	247,5	415	170
CHV500.35	35°	427,78	150,13	80	327	247	145	408	340	190	438	175	365	83	256,5	415	110
CHV500.40	40°	438,66	158,34	80	320	240	145	408	340	190	438	175	365	83	265,5	415	110
CHV500.45	45°	395,15	172,88	30	255	225	145	408	340	190	438	175	401	103	224,5	455	110
CHV500.50	50°	412,72	188,31	30	253	223	145	408	340	190	438	175	401	100,5	233,5	450	110
CHV500.55	55°	423,22	212,08	30	262	232	145	408	340	190	438	175	401	100,5	241	450	110
CHV500.60	60°	433,59	232,11	30	259	229	145	408	340	190	438	175	401	100,5	248,5	450	110
CHV500.65	65°	434,62	242,64	0	250	250	140	500	463	463	500	175	401	100,5	248,5	450	110
CHV500.70	70°	429,87	254,52	0	228	228	125	500	463	463	500	175	401	100,5	248,5	450	110
CHV500.75	75°	418,49	262,53	0	213	213	105	500	463	463	500	160	401	100,5	233,5	450	110



AERIAL CAM UNIT - OBEN HÄNGENDER SCHIEBER - UNITÀ A CAMME SOSPESA

X VIEW

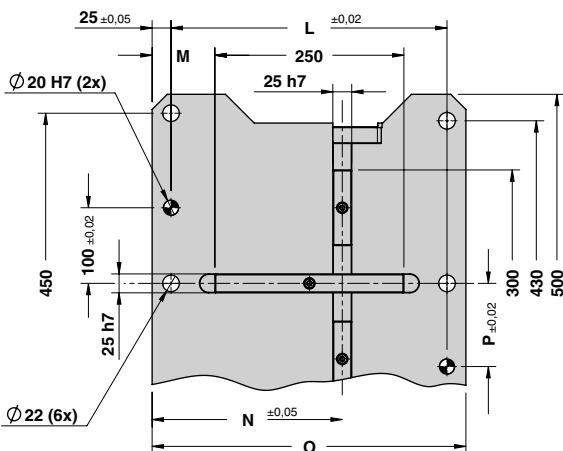
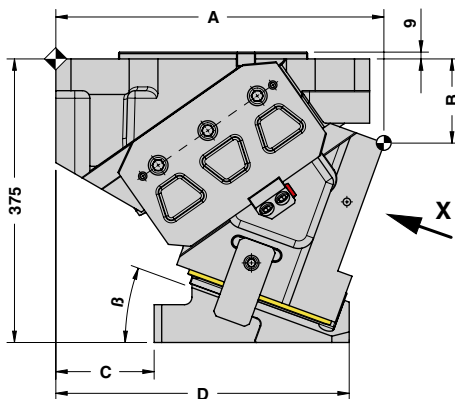
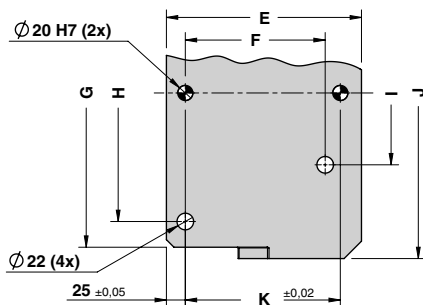
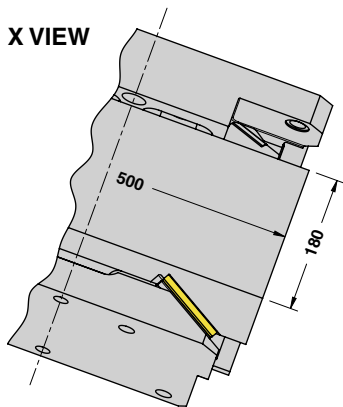

Cam Units CHV



CAM DIAGRAM WITH ACCELERATOR

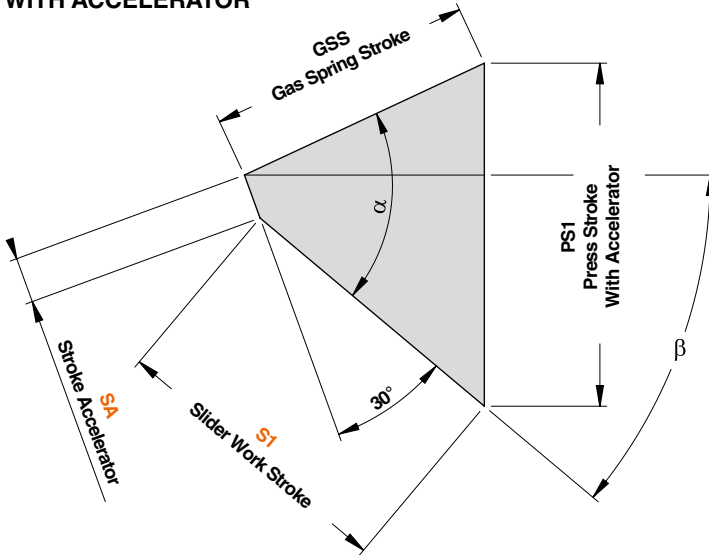

CAM DIAGRAM WITHOUT ACCELERATOR

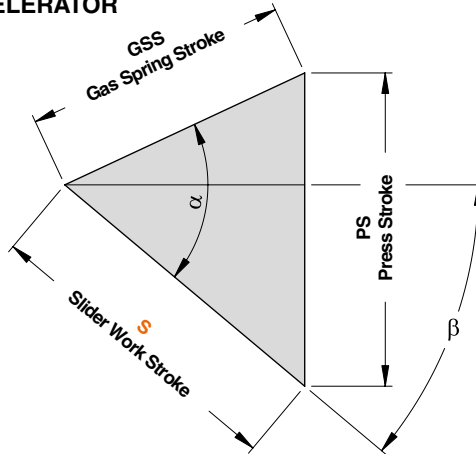



**AERIAL CAM UNIT - OBEN HÄNGENDER SCHIEBER - UNITÀ A CAMME SOSPESA**

OMCR CODE	Work Angle	Inner Angle	Slider Work Stroke (mm)		Press Stroke (mm)		Stroke Accelerator	Gas Spring Stroke (mm)
	$\beta$	$\alpha$	S	S1	Ps	Ps1	SA	Gss
CHV500.00	0°	50°	37,28	28,62	44,43	49,43	10	58
CHV500.05	5°	50°	41,17	32,94	44,60	49,62	10	58
CHV500.10	10°	55°	41,64	33,87	48,24	53,32	10	58
CHV500.15	15°	55°	46,00	38,68	49,19	54,36	10	58
CHV500.20	20°	55°	50,56	43,71	50,56	55,89	10	58
CHV500.25	25°	60°	52,42	46,09	55,42	60,94	10	58
CHV500.30	30°	60°	58,00	52,22	58,00	63,78	10	58
CHV500.35	35°	65°	61,32	56,16	64,17	70,27	10	58
CHV500.40	40°	65°	68,62	64,15	68,62	75,15	10	58
CHV500.45	45°	70°	74,34	70,68	77,08	84,15	10	58
CHV500.50	50°	70°	84,79	82,09	84,79	92,57	10	58
CHV500.55	55°	75°	95,02	-	97,67	-	-	58
CHV500.60	60°	75°	112,05	-	112,05	-	-	58
CHV500.65	65°	80°	102,85	-	104,86	-	-	45
CHV500.70	70°	85°	127,09	-	131,07	-	-	45
CHV500.75	75°	85°	114,15	-	115,47	-	-	30

Cam Units CHV



AERIAL CAM UNIT - OBEN HÄNGENDER SCHIEBER - UNITÀ A CAMME SOSPESA

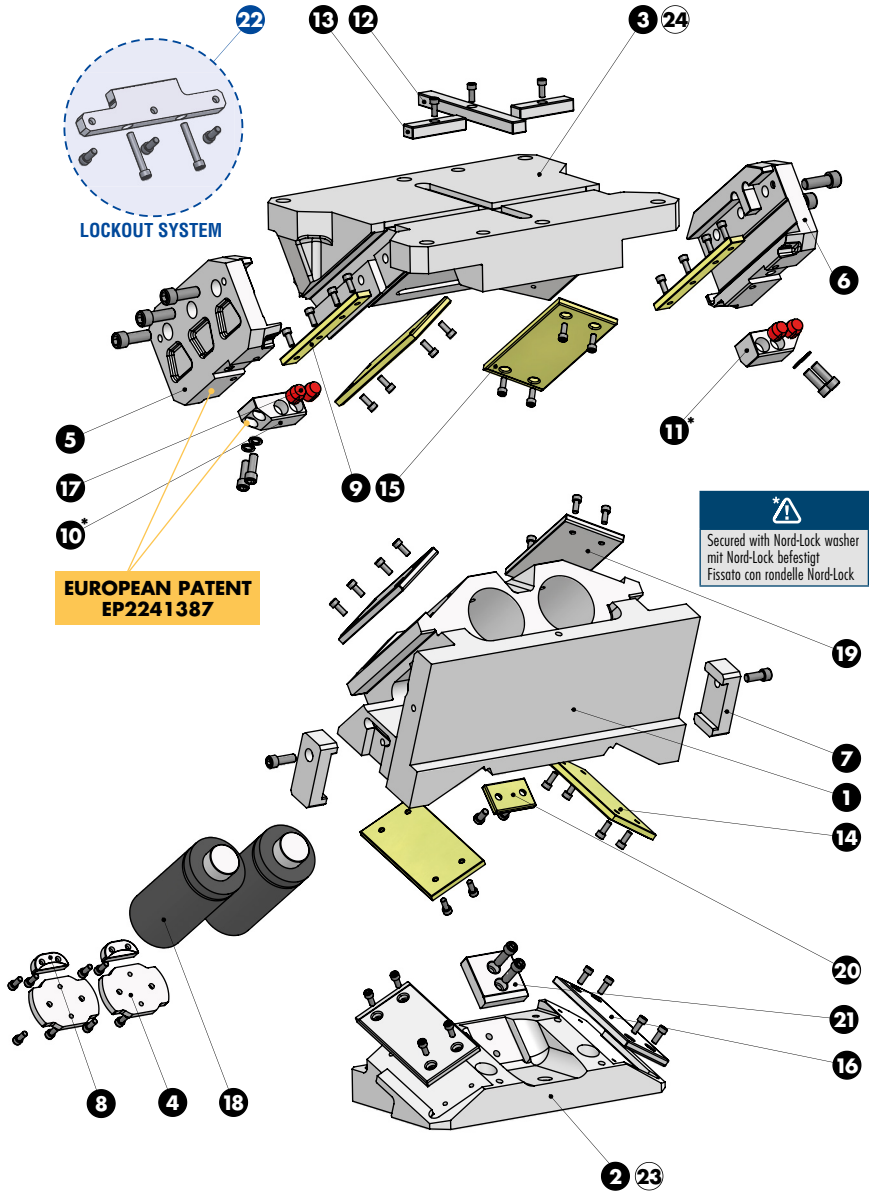



**AERIAL CAM UNIT - OBEN HÄNGENDER SCHIEBER - UNITÀ A CAMME SOSPESA**

SLIDER STRUCTURE, POSITIVE RETURN STRUCTURE AND CLEARANCES

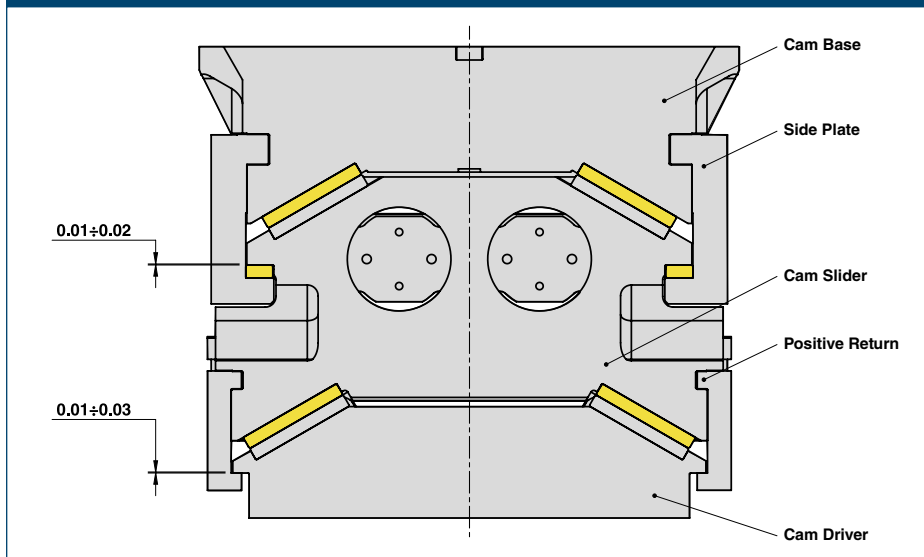

Cam Units CHV

PART LIST

Particular number	Description	Material	Quantity
1	Cam Slider	GGG-60	1
2	Cam Driver	GGG-60	1
3	Cam Base	GGG-60	1
4	Lock Plate	42CrMo4	2
5	Side Plate L	42CrMo4	1
6	Side Plate R	42CrMo4	1
7	Positive Return	42CrMo4 Nitrided	2
8	Safety Plate	CK45	2
9	Wear Plate	CuZn25Al5 + Graphite - HB > 190	2
10	Slide Reaction L	CK45	1
11	Slide Reaction R	CK45	1
12	Key	CK45	1
13	Key	CK45	2
14	Wear Plate VDI 3357	CuZn25Al5 + Graphite - HB > 190	2
15	Wear Plate VDI 3357	CuZn25Al5 + Graphite - HB > 190	2
16	Wear Plate VDI 3357	16MnCr5 - HRC 58-60	2
17	Elastomer Cap	Elastomer 92SH	4
18	Gas Spring	-	2
19	Wear Plate VDI 3357	16MnCr5 - HRC 58-60	2
20	Wear Plate	CuZn25Al5 + Graphite - HB > 190	1
21	Wear Plate VDI 3357	16MnCr5 - HRC 58-60	1
22	LOCKOUT SYSTEM	(more info on OMCR website)	1
23	Cam Driver Fixing Screws M20x70 DIN 912	-	4
24	Cam Base Fixing Screws M20x70 DIN 912	-	6





## AERIAL CAM UNIT - OBEN HÄNGENDER SCHIEBER - UNITÀ A CAMME SOSPESA

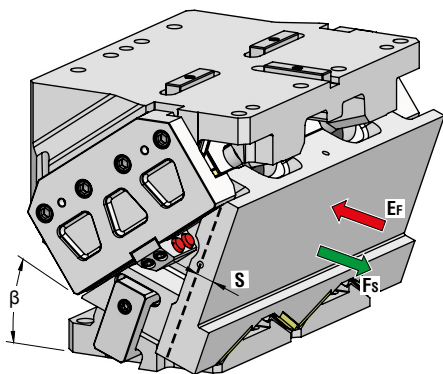

OMCR CODE	Work Angle	Stroke (mm)	Max Work Force with shoulder (kN)	Extraction Force (kN)
	β	S	Fs	Ef Gas Spring
CHV600.00	0°	37,28	1202	98,1
CHV600.05	5°	41,17	1202	98,1
CHV600.10	10°	41,64	1202	98,5
CHV600.15	15°	46,00	1202	98,5
CHV600.20	20°	50,56	1202	98,5
CHV600.25	25°	52,42	1202	98,2
CHV600.30	30°	58,00	1202	98,2
CHV600.35	35°	61,32	1202	97,1
CHV600.40	40°	68,62	1202	97,1
CHV600.45	45°	74,34	1202	95,2
CHV600.50	50°	84,79	1202	95,2
CHV600.55	55°	95,02	1202	92,6
CHV600.60	60°	112,05	1202	92,6
CHV600.65	65°	102,85	1202	88,8
CHV600.70	70°	127,09	1202	84,9
CHV600.75	75°	114,15	1202	84,2

30

ORDER EXAMPLE

Art.	Work Angle = 5°
CHV600	05

OMCR CODE	Work Angle	Overall Dimensions (mm)																		
		β	A	B	C	D	E	F	G	H	I	J	K	L	M	N	O	P	Q	R
CHV600.00	0°	368,00	75,00	120	375	255	205	25	180	200	30	330	360	272,5	167,5	600	560	250	25	385
CHV600.05	5°	377,63	89,37	105	363	258	210	25	180	205	30	330	360	272,5	182,5	600	560	250	25	385
CHV600.10	10°	387,28	99,59	105	350	245	205	25	180	200	30	330	360	272,5	192,5	600	560	250	15	385
CHV600.15	15°	396,88	110,64	95	340	245	195	25	180	190	30	330	360	272,5	207,5	600	560	250	25	385
CHV600.20	20°	391,35	122,53	55	315	260	210	25	180	205	30	325	355	267,5	207,5	530	280	90	25	380
CHV600.25	25°	400,61	135,23	55	305	250	200	25	180	195	30	325	355	267,5	222,5	530	280	90	25	380
CHV600.30	30°	409,61	138,74	45	295	250	200	25	180	195	30	345	375	287,5	222,5	530	280	90	25	400
CHV600.35	35°	418,26	153,01	5	285	280	225	25	180	220	30	355	385	302,5	202,5	530	280	90	30	415
CHV600.40	40°	426,51	168,02	5	280	275	225	25	180	220	30	380	410	322,5	217,5	530	280	90	25	435
CHV600.45	45°	434,30	183,73	5	270	265	215	25	180	210	30	380	410	322,5	242,5	530	280	90	25	435
CHV600.50	50°	419,53	180,82	-5	220	225	175	25	180	170	30	400	430	342,5	232,5	530	280	100	25	455
CHV600.55	55°	427,80	199,87	-5	210	215	165	25	180	160	30	400	430	342,5	247,5	530	280	100	25	455
CHV600.60	60°	425,24	224,61	-15	200	215	165	25	180	160	30	400	430	342,5	267,5	530	280	100	25	455
CHV600.65	65°	431,81	244,96	5	190	185	140	35	160	130	55	415	470	382,5	262,5	600	560	250	25	495
CHV600.70	70°	437,45	270,84	5	185	180	135	35	160	125	55	415	470	382,5	262,5	600	560	250	25	495
CHV600.75	75°	442,12	292,17	5	180	175	120	35	160	130	55	415	470	382,5	327,5	600	560	250	25	495



AERIAL CAM UNIT - OBEN HÄNGENDER SCHIEBER - UNITÀ A CAMME SOSPESA

X VIEW

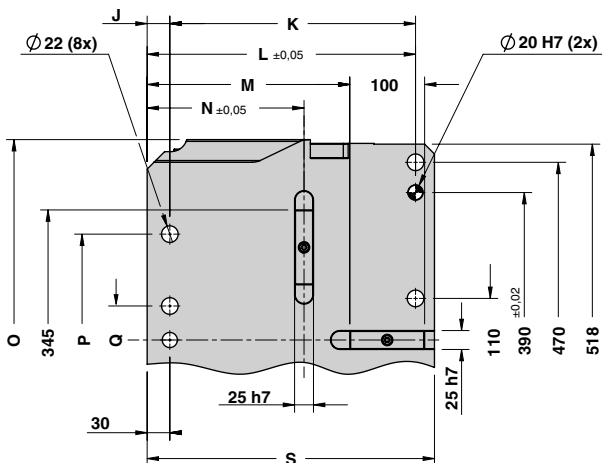
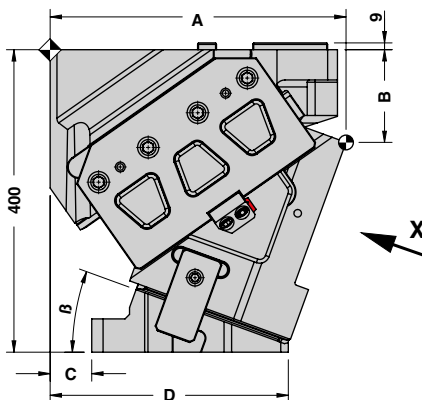
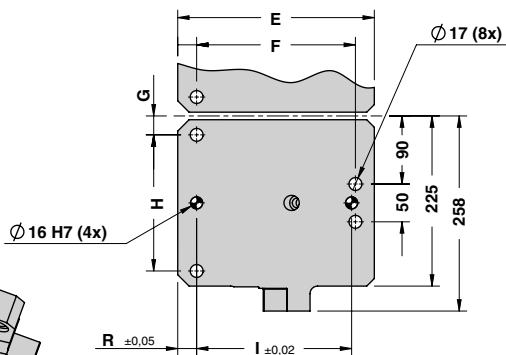
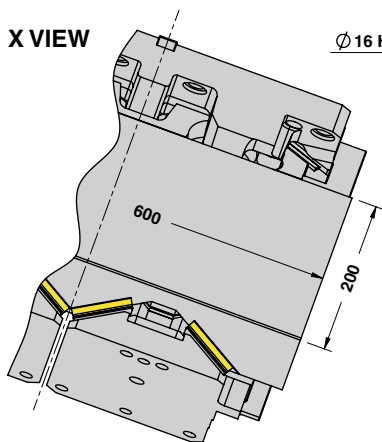

Cam Units CHV



AERIAL CAM UNIT - OBEN HÄNGENDER SCHIEBER - UNITÀ A CAMME SOSPESA



CAM DIAGRAM WITH ACCELERATOR

WEB

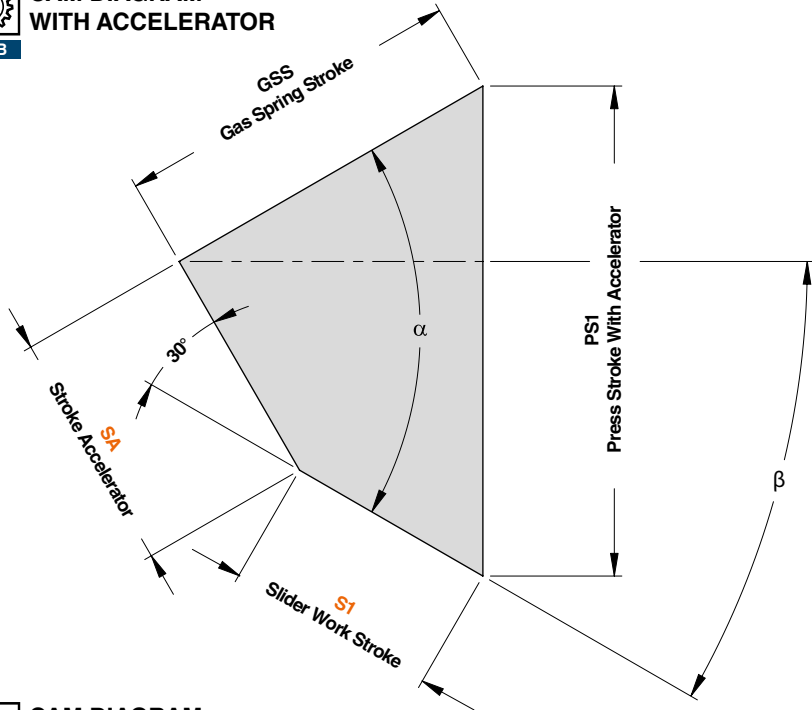

CAM DIAGRAM WITHOUT ACCELERATOR

WEB

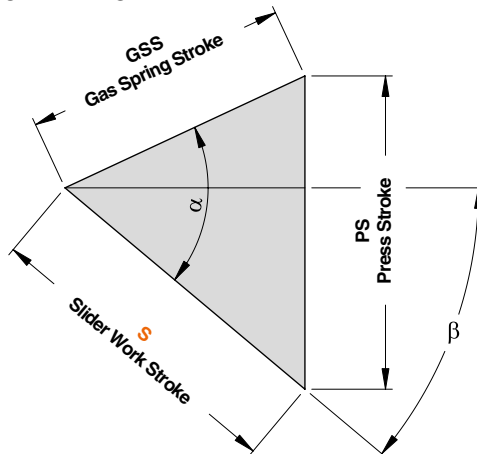



**AERIAL CAM UNIT - OBEN HÄNGENDER SCHIEBER - UNITÀ A CAMME SOSPESA**

OMCR CODE	Work Angle	Inner Angle	Slider Work Stroke (mm)		Press Stroke (mm)		Stroke Accelerator	Gas Spring Stroke (mm)
	$\beta$	$\alpha$	S	S1	Ps	Ps1	SA	Gss
CHV600.00	0°	50°	37,28	25,00	44,43	51,52	14,18	58
CHV600.05	5°	50°	41,17	25,00	44,60	54,47	19,66	58
CHV600.10	10°	55°	41,64	25,00	48,24	59,11	21,40	58
CHV600.15	15°	55°	46,00	35,00	49,19	56,96	15,02	58
CHV600.20	20°	55°	50,56	35,00	50,56	62,66	22,75	58
CHV600.25	25°	60°	52,42	35,00	55,42	70,61	27,53	58
CHV600.30	30°	60°	58,00	35,00	58,00	81,00	39,84	58
CHV600.35	35°	65°	61,32	40,00	64,17	89,39	41,32	58
CHV600.40	40°	65°	68,62	50,00	68,62	95,84	41,70	58
CHV600.45	45°	70°	74,34	55,00	77,08	114,44	52,84	58
CHV600.50	50°	70°	84,79	77,00	84,79	107,22	28,84	58
CHV600.55	55°	75°	95,02	-	97,67	-	-	58
CHV600.60	60°	75°	112,05	-	112,05	-	-	58
CHV600.65	65°	80°	102,85	-	104,86	-	-	45
CHV600.70	70°	85°	127,09	-	131,07	-	-	45
CHV600.75	75°	85°	114,15	-	115,47	-	-	30

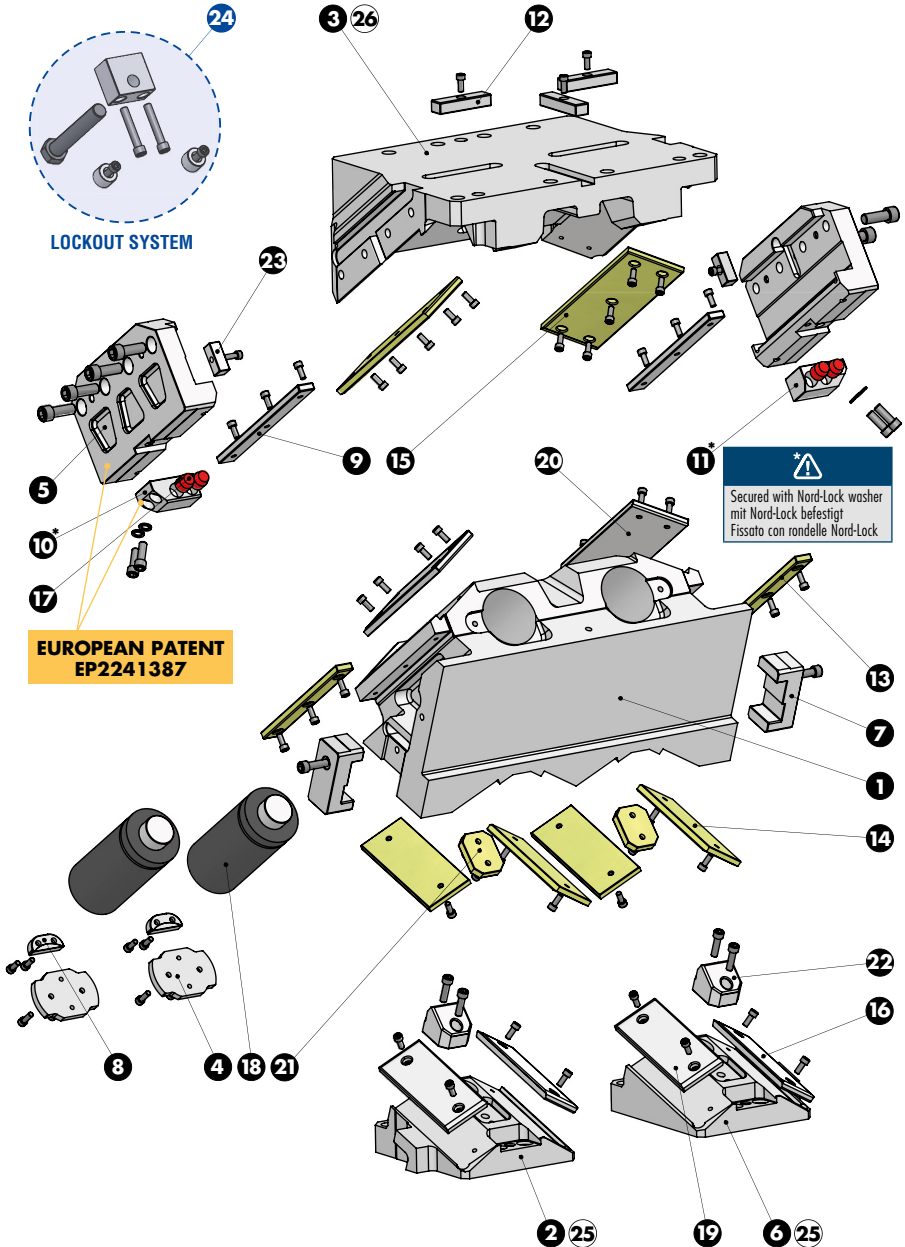

## AERIAL CAM UNIT - OBEN HÄNGENDER SCHIEBER - UNITÀ A CAMME SOSPESA





**AERIAL CAM UNIT - OBEN HÄNGENDER SCHIEBER - UNITÀ A CAMME SOSPESA**

SLIDER STRUCTURE, POSITIVE RETURN STRUCTURE AND CLEARANCES

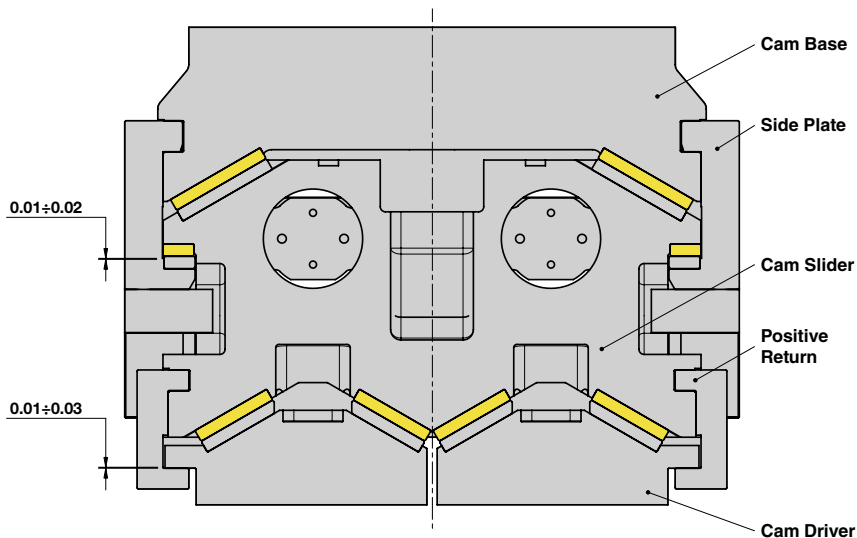

PART LIST

Particular number	Description	Material	Quantity
1	Cam Slider	GGG-60	1
2	Cam Driver L	GGG-60	1
3	Cam Base	GGG-60	1
4	Lock Plate	42CrMo4	2
5	Side Plate	42CrMo4	2
6	Cam Driver R	GGG-60	1
7	Positive Return	42CrMo4 Nitrided	2
8	Safety Plate	CK45	2
9	Wear Plate	16MnCr5 - HRC 58-60	2
10	Slide Reaction L	CK45	1
11	Slide Reaction R	CK45	1
12	Key	CK45	3
13	Wear Plate	CuZn25Al5 + Graphite - HB > 190	2
14	Wear Plate VDI 3357	CuZn25Al5 + Graphite - HB > 190	4
15	Wear Plate VDI 3357	CuZn25Al5 + Graphite - HB > 190	2
16	Wear Plate VDI 3357	16MnCr5 - HRC 58-60	2
17	Elastomer Cap	Elastomer 92SH	4
18	Gas Spring	-	2
19	Wear Plate VDI 3357	16MnCr5 - HRC 58-60	2
20	Wear Plate VDI 3357	16MnCr5 - HRC 58-60	2
21	Wear Plate	CuZn25Al5 + Graphite - HB > 190	2
22	Accelerator	CK45	2
23	Key	CK45	2
24	<b>LOCKOUT SYSTEM</b>	(more info on OMCR website)	1
25	Cam Driver Fixing Screws M16x60 DIN 912	-	8
26	Cam Base Fixing Screws M20x70 DIN 912	-	8

Cam Units CHV